

TECHNICAL DOCUMENTATION
CRANE SYSTEM GISKB I | GISKB II

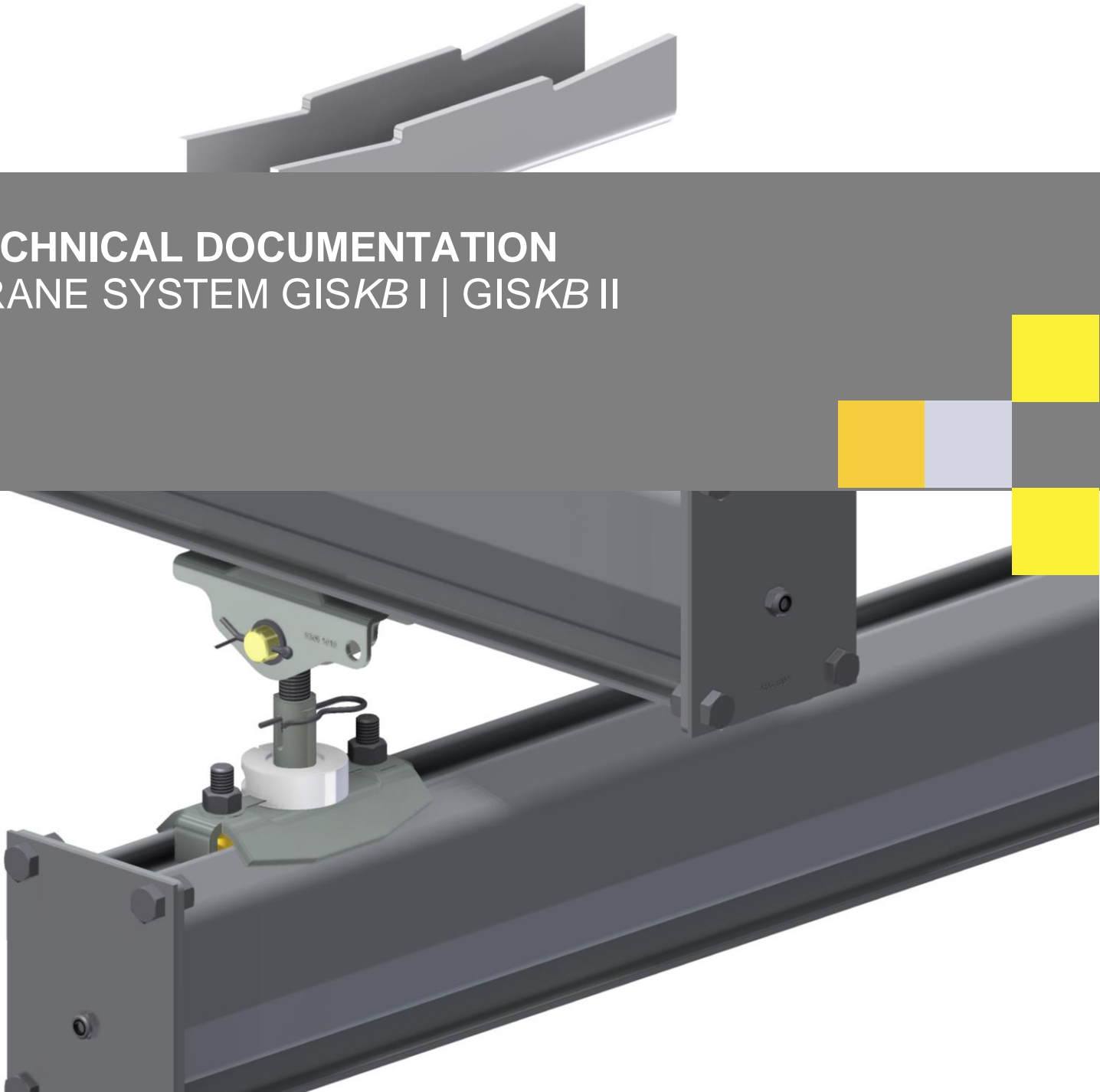

Table of contents

0	General instructions.....	4
0.1	Explanation of signs.....	4
1	Overview.....	5
1.1	Overview suspensions.....	6
2	Directives concerning the suspension points of GISKB small crane systems	7
2.1	Distanced monorails	7
2.2	Suspended cranes.....	7
2.3	Examples of bracings.....	7
3	Dimensioning suspended crane	8
3.1	Crane bridge.....	8
3.2	Crane track / Monorail.....	9
4	Dimensions and approach dimensions	10
5	Configuration example	11
6	Crane system components	13
6.1	Track section	13
6.2	Cover.....	14
6.3	Profile junction	14
6.4	Profile reinforcement.....	15
6.5	Clamping holder complete	16
6.6	Trolley.....	16
6.7	Traverse	17
6.8	Saddle	17
6.9	Overview crane bridge suspension	18
6.9.1	Simple crane bridge pendulating.....	18
6.9.2	Single crane bridge rigid	19
6.9.3	Double crane bridge rigid.....	20
6.10	Crane bridge suspension pendulating.....	21
6.11	Rolling apparatus.....	22
6.12	Reinforcement of rolling apparatus.....	22
6.13	Breaker	23
6.14	Suspension pendulating short	24
6.15	Suspension pendulating distanced.....	25
6.16	Bracing pendulating distanced	26
6.17	Suspension rigid direct.....	27
6.18	Ceiling clip	28
6.19	Binding clip complete	28
6.20	Support to ceiling clip.....	29
6.21	Lateral suspension.....	29
6.22	GIS adhesive	30
6.23	Lifting capacity adhesive	30
6.24	Electric tug.....	31
6.25	Connector clamp trolley	32
6.26	Connection clamp rolling apparatus	32
6.27	Bend.....	33
6.28	Conductor line VA24, 4-poles, bend.....	34
6.29	Track switch.....	35
6.30	Operation of track switch.....	36
6.31	Conductor line VA24, 4-poles, track switch	37
6.32	Interlocking devices	38
7	Power supply	39
7.1	Trailing cable	39
7.2	C-rail.....	40
7.3	Conductor line.....	41
7.4	Internal conductor line.....	42
7.5	Components	43

0 General instructions

This GIS documentation contains information about the lay-out and planning of GISKB suspended crane and monorail up to 1600 kg.







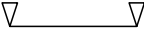
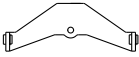
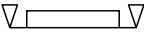

1. The documents allow you a fast and efficient dimensioning of the crane equipments.

Technical notes:

- The documents for planning are based on the rules of the latest technology.
- Only GIS originally manufactured parts shall be used.
- The customer is responsible for the stability of the ceiling structure.
- Painting: The crane equipment is delivered with a grey primer (RAL 7035).
On request, a finished paint is possible according to your choice or galvanised version.

2. For the components used, the technical specifications, dimensions and the order numbers are given.
3. A configuration example shows you how to reach the goal as fast as possible and where to find the relevant information in this documentation.
4. In the final pages of this document a questionnaire for the project of GIS light crane systems is added. It should help you to find the necessary data.

0.1 Explanation of signs

	Crane bridge		Saddle
	Reinforced crane bridge		Flange width [mm]
	Profile		Lifting capacity [kg]
	Trolley		Dead weight [kg]
	Traverse		Electric mains for power supply
	Rolling apparatus	N°	Ordering number

1 Overview

Single bridge suspension crane

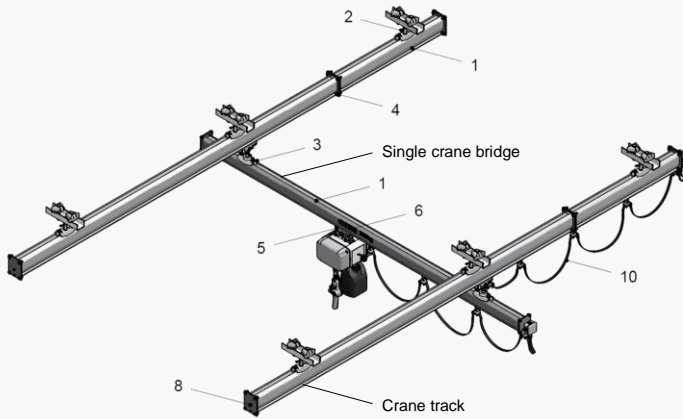

Double bridge suspension crane

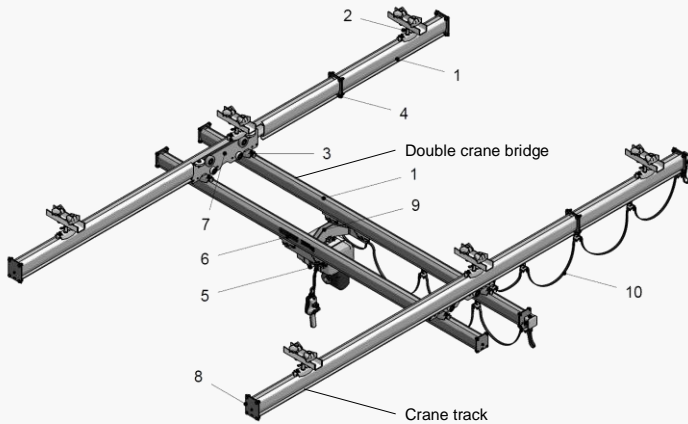

Monorail

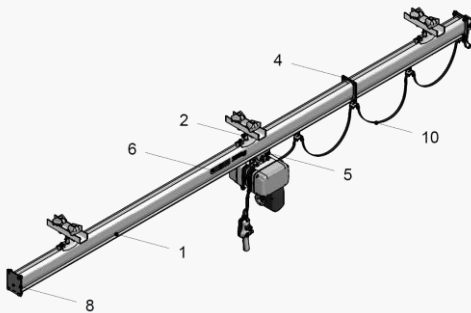

	Page
1 Track section	13
2 Suspension	6
3 Crane bridge suspension.....	18-20
4 Profile junction	14
5 Trolley	16
6 Lifting capacity adhesive	30
7 Rolling apparatus.....	22
8 Cover	14
9 Saddle.....	17
10 Power supply	39

1.1 Overview suspensions

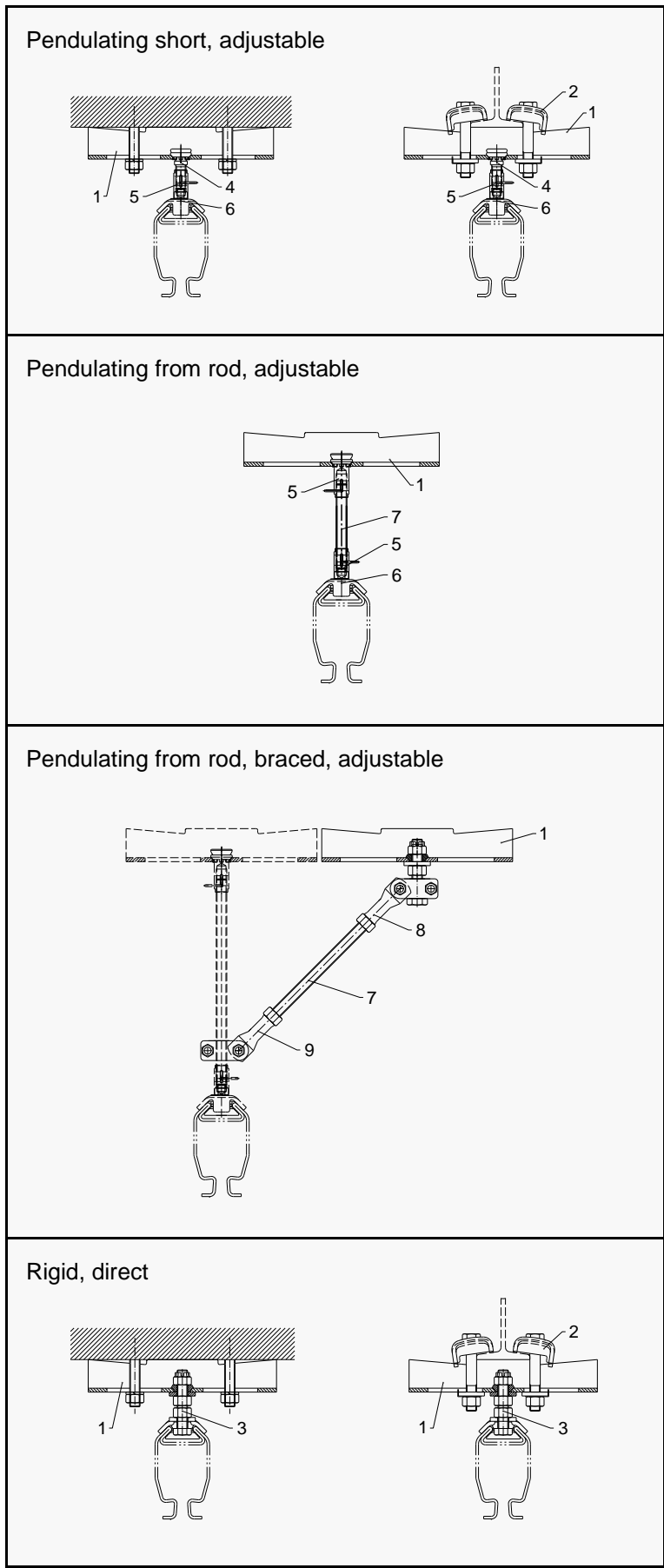

	Page
1 Ceiling clip.....	28
2 Binding clip complete.....	28
3 Suspension rigid.....	27
4 Ball pin complete.....	24
5 Ball nut complete.....	24
6 Profile retainer complete.....	24
7 Threaded rod.....	25
8 Knots top.....	26
9 Knots bottom.....	26

2 Directives concerning the suspension points of GISKB small crane systems

The distances between the suspension points depend on the profile size and the strain. This dimensioning is made according to the diagrams or the calculation program.

The type of suspension depends on the constructional situation. The short suspension can be of rigid or pendulating type. The suspensions from rod are available pendulating only. Pendulating suspensions are easier to assemble. Inaccurate alignment due to imprecise ceiling structures can be avoided. Care is to be taken that the angle of the suspension does not differ more than 5° from the vertical position.

2.1 Distanced monorails

Monorails suspended from rods must not be braced imperatively provided that no side dragging of hoist exists. Practice, however, shows that a side dragging cannot be excluded, wherefore bracings are to be provided.

For distanced suspensions greater than or equal to $h_4 = 500$ mm (see page 10) transverse and longitudinal bracings are provided. Longitudinal bracings are to be provided for both track ends and lateral bracings for every second suspension.

Monorails with bends and track switches: See to the special guide notes for "Bends and track switches".

2.2 Suspended cranes

Combinations for pendulating and rigid suspensions:

If the crane track is suspended from the ceiling pendulating, the crane bridge can pendulating or is rigidly connected to the crane track (see page 18 - 19). If the crane track is suspended rigidly, the crane bridge must also be rigidly connected to the crane track (see page 19). Double crane bridges must always be rigidly suspended from the crane track (see page 20).

From the ceiling hung distanced crane tracks:

If the suspended cranes are greater than or equal to $h_4 = 500$ mm (see page 10) suspended from the ceiling, both crane tracks have to be braced longitudinally and a crane track lateral. Longitudinal bracings are to be provided for all track ends. Lateral bracings are to be provided for every second suspension only on one crane track.

2.3 Examples of bracings

Monorail (distance greater than or equal to 500 mm)

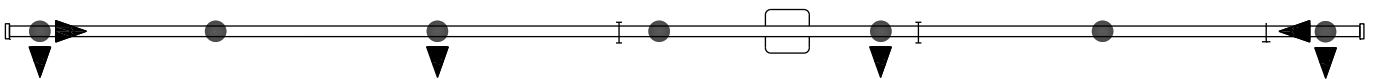

Suspended crane (distance greater than or equal to 500 mm)

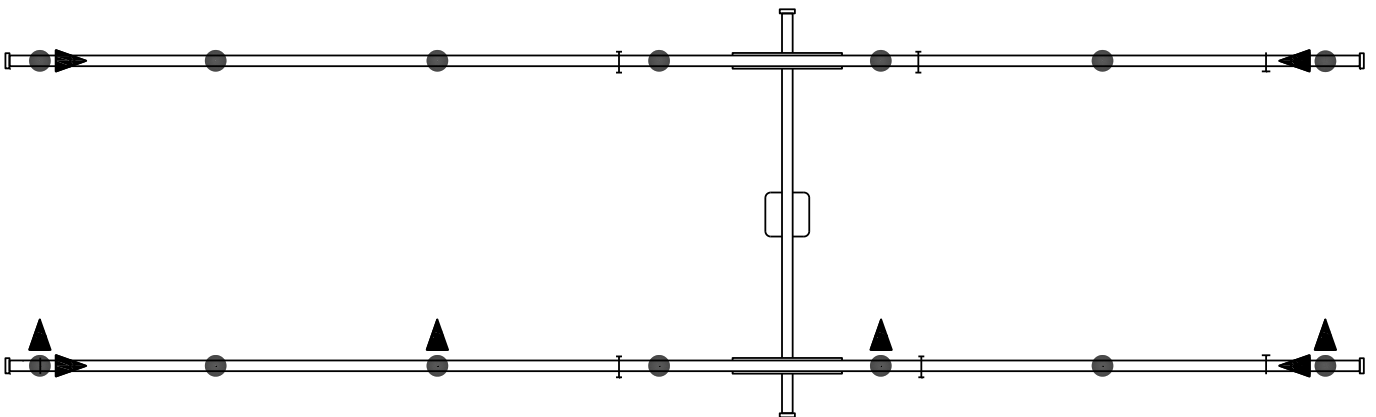

● Symbol suspension

▶ Symbol bracing

3 Dimensioning suspended crane

3.1 Crane bridge

The selection of the profile size depends on the strength (P) and the span (W) of the profile. In tables 3-1 (single crane bridge) and 3-2 (double crane bridge) the adequate profile size can be found.

Load : The strength (P) does include the dead weight of the electric chain hoist and the trolley. The max. admissible load is as follows: GISKB I = 800 kg / GISKB II = 1600 kg.

Length of span . : The admissible span is shown in the table, depending on the type of profile. Its maximum is 7800 mm.

The calculations in tables 3-1 and 3-2 are based on a permissible deflection of $W / 400$. The classification of cranes is according to EN 13001: HC4; U2-U3; Q0-Q4; S0-S2 and EN 15018: H2/H3; B3/B4. For other deflection factors there is a calculation program at your disposal.

Admissible load overhang (y): In crane bridges load overhang is permitted only when calculated with the calculation program.

 without reinforcement

 with reinforcement

Table 3-1 Single crane bridge span W [m]

















Lifting capacity	GISKB I				GISKB II			
								
80 kg	5.1	7.8	7.8	7.8	7.6	7.8	7.8	7.8
100 kg	4.8	7.8	7.8	7.8	7.2	7.8	7.8	7.8
125 kg	4.5	7.8	7.8	7.8	6.9	7.8	7.8	7.8
160 kg	4.1	7.8	7.8	7.8	6.4	7.8	7.8	7.8
200 kg	3.8	7.6	7.8	7.8	6.0	7.8	7.8	7.8
250 kg	3.5	7.2	7.8	7.8	5.6	7.8	7.8	7.8
320 kg	3.1	6.7	7.8	7.8	5.1	7.8	7.8	7.8
400 kg	2.8	6.3	7.7	7.8	4.7	7.5	7.8	7.8
500 kg	2.6	5.8	7.3	7.8	4.3	7.0	7.8	7.8
630 kg	2.2	5.0	6.5	7.3	3.8	6.4	7.8	7.3
800 kg	1.6	4.0	5.0	5.7	2.9	5.1	6.2	6.9
1000 kg	-	-	-	-	2.8	5.4	6.7	7.3
1250 kg	-	-	-	-	2.3	4.1	5.2	5.6
1600 kg	-	-	-	-	1.7	3.0	3.7	4.2

Table 3-2 Double crane bridge span W [m]

Lifting capacity	GISKB I				GISKB II			
								
80 kg	6.3	7.8	7.8	7.8	7.8	7.8	7.8	7.8
100 kg	6.0	7.8	7.8	7.8	7.8	7.8	7.8	7.8
125 kg	5.7	7.8	7.8	7.8	7.8	7.8	7.8	7.8
160 kg	5.4	7.8	7.8	7.8	7.8	7.8	7.8	7.8
200 kg	5.0	7.8	7.8	7.8	7.4	7.8	7.8	7.8
250 kg	4.7	7.8	7.8	7.8	7.1	7.8	7.8	7.8
320 kg	4.3	7.8	7.8	7.8	6.6	7.8	7.8	7.8
400 kg	3.9	7.7	7.8	7.8	6.1	7.8	7.8	7.8
500 kg	3.6	7.3	7.8	7.8	5.7	7.8	7.8	7.8
630 kg	3.2	6.8	7.8	7.8	5.2	7.8	7.8	7.8
800 kg	2.9	6.3	7.8	7.8	4.7	7.5	7.8	7.8
1000 kg	2.6	5.8	7.3	7.8	4.3	7.0	7.8	7.8
1250 kg	2.3	5.3	6.7	7.4	3.9	6.5	7.8	7.8
1600 kg	1.7	3.9	5.2	5.8	3.4	5.9	7.3	7.8

3.2 Crane track / Monorail

The span A is based on the diagrams 3-3 (GISKB I) and 3-4 (GISKB II). The maximum spans are different in the end field (EF) or middle field (MF). The 1 field solution (1F) has only 2 suspension points and must be calculated separately. The load on the crane track or monorail is calculated using the following formulas:

Crane track:

$$P_{KB} = 1.29 \times P_H + 1.1 \times (P_1 + 0.5 \times P_{KT})$$

P_{KB} = load crane track [kg]

P_{HB} = load monorail [kg]

P_H = permissible lifting capacity [kg]

P_1 = dead weight trolley and electric chain hoist [kg]

P_{KT} = dead weight crane bridge [kg]

Monorail:

$$P_{HB} = 1.29 \times P_H + 1.1 \times P_1$$

The length ratio between two adjacent fields must not exceed the value of 1.5 and not fall below the value of 0.5.

Admissible distance of joints (x): The junction of two track sections shall be at a distance of max. 0.2 x A and a min. of 100 mm from the nearest suspension point.

Admissible load overhang (y) ...: In case of crane tracks and monorails the load overhang can only be dimensioned with the calculation program.

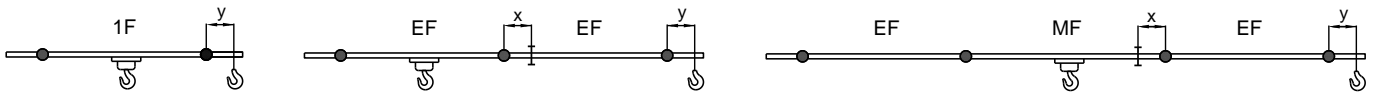

Diagram 3-3 GISKB I

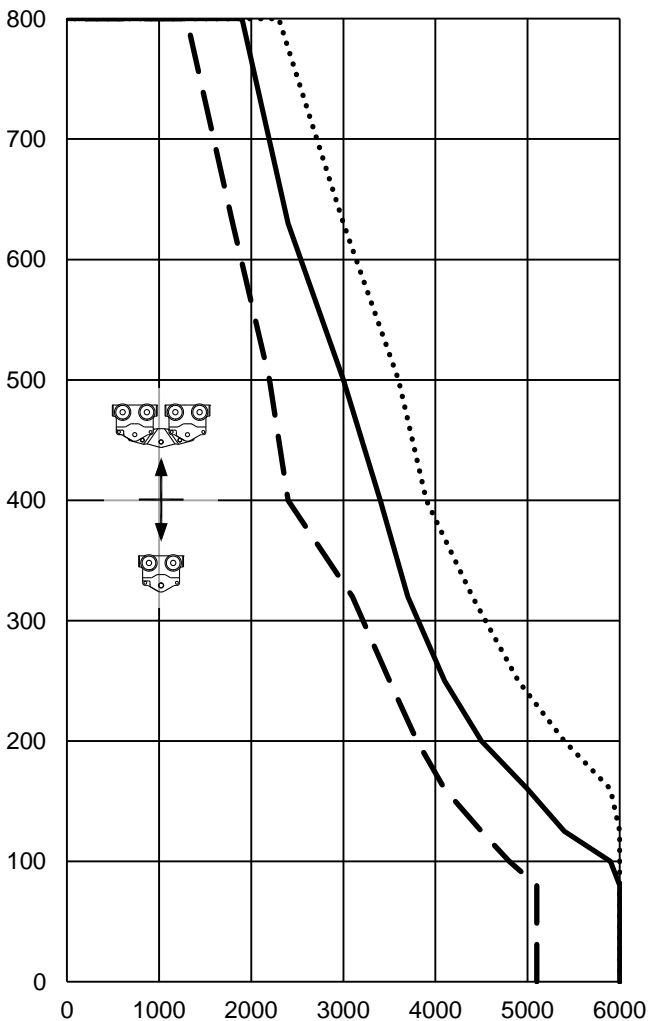
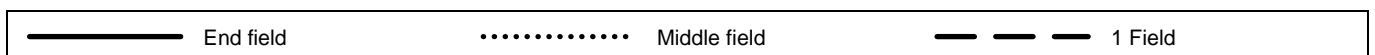
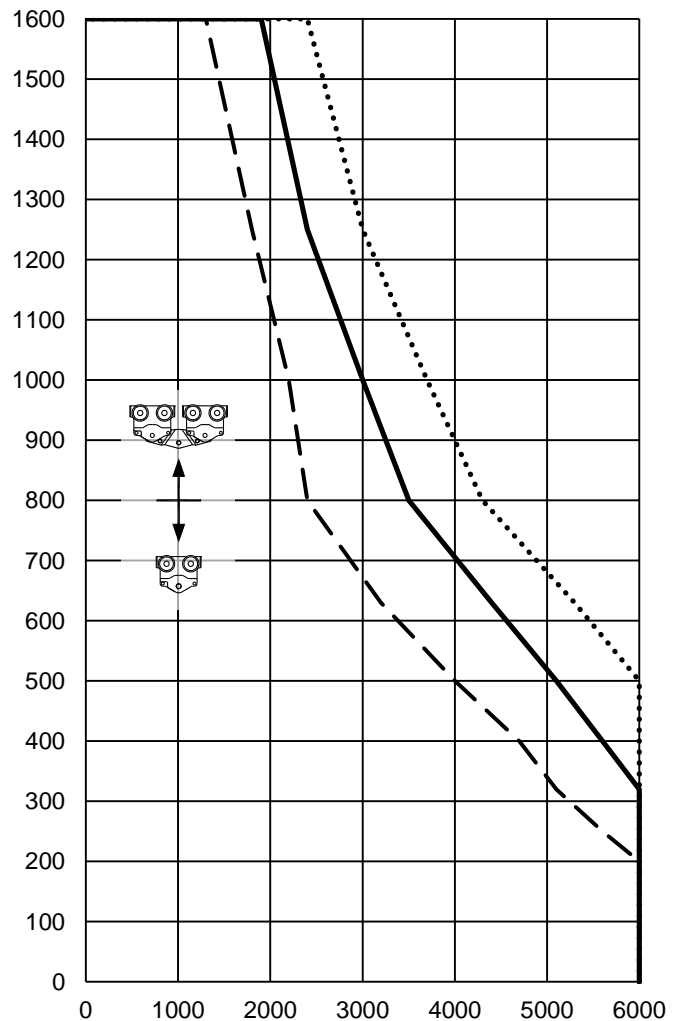
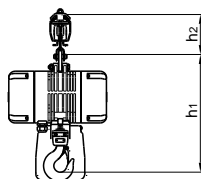
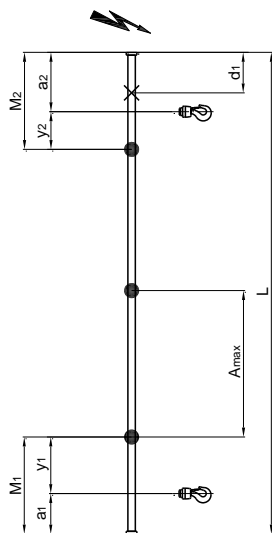
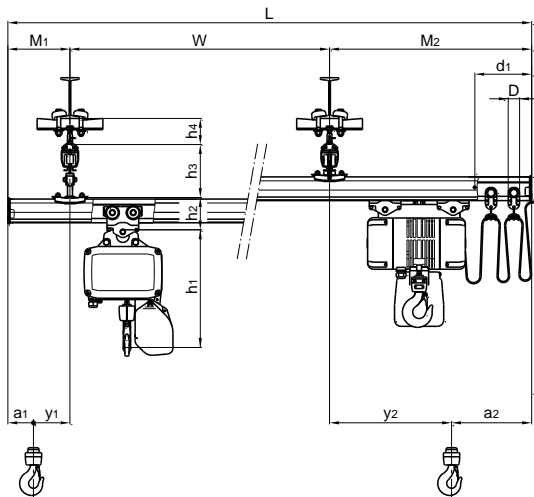
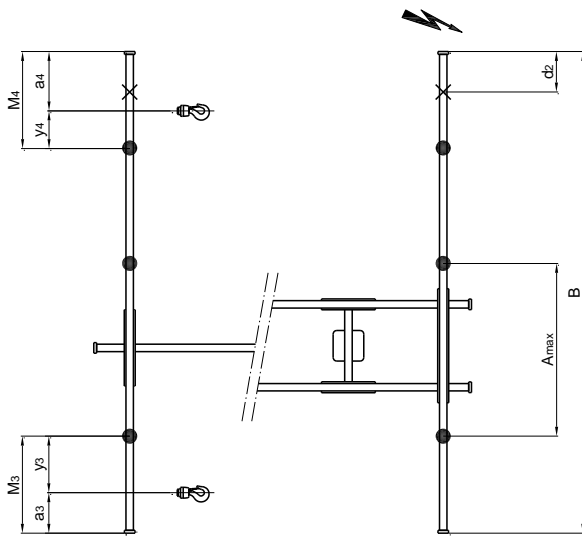

Diagram 3-4 GISKB II



4 Dimensions and approach dimensions



		GISKB I	GISKB II
a ₁ a ₃		110 mm	125 mm
a ₁ a ₃		230 mm	245 mm
a ₁		260 mm	275 mm
a ₃		330 mm	330 mm
h ₁	[mm]	see dimensions of electric chain hoist	
h ₂		143 mm	181 mm
h ₂		175 mm	214 mm
h ₂		112 mm	151 mm
h ₃ pendelnd		228 mm	266 mm
h ₃ pendelnd		260 mm	299 mm
h ₃ starr		147 mm	186 mm
h ₄ pendulating, short		120 ±7.5 mm	120 ±7.5 mm
h ₄ rigid, direct		95 mm	95 mm
a ₂	[mm]	$a_1 + 25 + (x_1 \cdot D)$	
a ₄	[mm]	$a_3 + 25 + (x_2 \cdot D)$	
M ₁	[mm]	$a_1 + y_1$	
M ₂	[mm]	$a_2 + y_2$	
M ₃	[mm]	$a_3 + y_3$	
M ₄	[mm]	$a_4 + y_4$	
d ₁ / d ₂	[mm]	$40 + (x_{1(2)} \cdot D)$	
y _{max.}	[mm]	see page 8 - 9	
A _{max.}	[mm]	see page 9	
W	[mm]	see table 3-1 and table 3-2 page 8	
x ₁	[Piece]	Cable carriages crane bridge (L:1250)-1	
x ₂	[Piece]	Cable carriages crane track (B:1250)-1	
D	[mm]	Cable carriage = 50	

5 Configuration example

Single bridge suspended crane: Lifting capacity 500 kg
 Load overhang y_1 and y_2 as big as possible
 Crane bridge length $L = 6000$ mm
 Infrastructure lengthwise approximately 13500 mm
 Crane track length B after result
 Free choice for suspension points, direct on to steel structure, pendulating
 Crane drive (longitudinal) and trolley drive (cross) manual
 Power supply trailing cables

Dimensions

Simple crane bridge	Load 500 kg, $W = 5125$ mm; see table 3-1, page 8	selected GISKB II, Profile reinforcement IPE 120
Load overhang	see page 8; GISKB II with reinforcement; $y_1 = y_2 =$	chosen 100 mm
Crane bridge length	$L = W + M_1 + M_2 = 5125$ mm + 225 mm + 650 mm =	6000 mm
Crane track	see page 9	selected GISKB I
Load	$P_{KB} = 1.29 \cdot P_H + 1.1 \cdot (P_1 + 0.5 \cdot P_{KT}) = 1.29 \cdot 500$ kg + 1.1 · (28 kg + 0.5 · 162 kg) = 765 kg $P_H =$ admissible lifting capacity = 500 kg $P_1 =$ Dead weight trolley + electric chain hoist = 3 kg + 25 kg = 28 kg $P_{KT} =$ Dead weight crane bridge + reinforcement + trolley longit. = 6 · 15 kg + 4.725 · 11.1 kg + 2 · 9.4 kg = 162 kg	
Span A_{EF}	End field; see diagram 3-3, page 9; GISKB I	2000 mm
Span A_{MF}	Middle field; see diagram 3-3, page 9; GISKB I	2400 mm
Load overhang	see page 9; GISKB I; $y_3 = y_4 =$	chosen 0 mm
Crane track length	$B = 2 \cdot A_{EF} + 5 \cdot A_{MF} + M_3 + M_4 = 2 \cdot 1900$ mm + 5 · 2200 mm + 100 mm + 100 mm = 15000 mm	
Number of cable carriages		
x_1 crane bridge	$(6000 \text{ mm} : 1250 \text{ mm}) - 1 = 3.8$	selected 4 pieces
x_2 crane track	$(15000 \text{ mm} : 1250 \text{ mm}) - 1 = 11$	selected 11 pieces
Dimension mass $a_1 - a_4$		
a_1 per table page 10	GISKB II	125 mm
a_2 per table page 10	$a_1 + 25 + (x_1 \cdot D) = 125$ mm + 25 mm + (4 · 50 mm) =	350 mm
a_3 per table page 10	GISKB I	330 mm
a_4 per table page 10	$a_3 + 25 + (x_2 \cdot D) = 230$ mm + 25 mm + (11 · 50 mm) =	905 mm
Load overhang $y_1 - y_4$		
$y_1 = y_2$	GISKB II with reinforcement	selected 100 mm
$y_3 = y_4$	GISKB I	selected 0 mm
Profile overhang $M_1 - M_4$		
M_1 per table page 10	$a_1 + y_1 = 125$ mm + 100 mm	225 mm
M_2 per table page 10	$a_2 + y_2 = 550$ mm + 100 mm	650 mm
M_3 per table page 10	$a_3 + y_3 = 230$ mm + 0 mm	selected 100 mm
M_4 per table page 10	$a_4 + y_4 = 1455$ mm + 0 mm	100 mm
Position of traction limit		
d_1 per table page 10	$40 + (x_1 \cdot D) = 40$ mm + (4 · 50 mm) =	240 mm
d_2 per table page 10	$40 + (x_2 \cdot D) = 40$ mm + (11 · 50 mm) =	590 mm
Height measures		
h_1 per data sheet	Electric chain hoist GCH 500/2 NF	417 mm
h_2 per table page 10	GISKB II	181 mm
h_3 per table page 10	GISKB I	147 mm

6 Crane system components

6.1 Track section

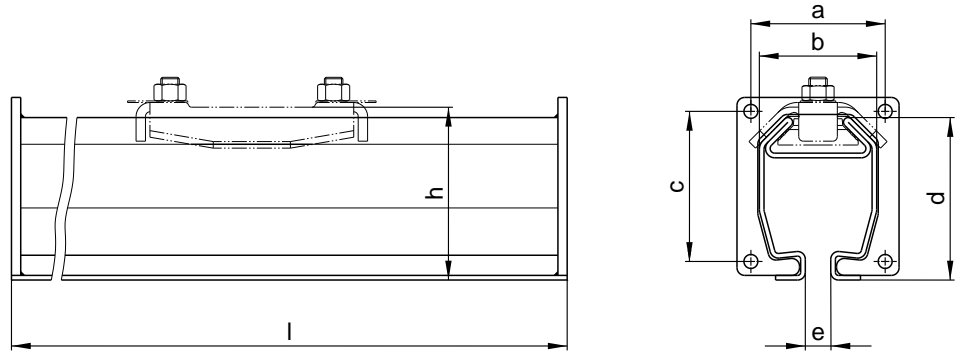

Version.....: GISKB I + II are profiles of special design, cold rolled and with a grey primer. An the end plate at the ends each is welded, which serves as a connecting plate for mounting the two profiles or profile cover.

Colour: RAL 7035 light grey.

Note: The dimensioning is made according to the appropriate documents (see page 8 - 9).

		GISKB I	GISKB II
 [kg/m]		10.000	16.000
a	[mm]	87	91
b	[mm]	76	84
c	[mm]	97	125
d	[mm]	105	142
e	[mm]	18	18
h	[mm]	112	150
W_x	[mm ³ x 10 ³]	25.38	52.26
I_x	[mm ⁴ x 10 ⁶]	1.436	4.087
l = 1 m		9305.1005.4	9306.1005.4
l = 2 m		9305.1006.4	9306.1006.4
l = 3 m		9305.1007.4	9306.1007.4
l = 4 m		9305.1008.4	9306.1008.4
l = 5 m		9305.1009.4	9306.1009.4
l = 6 m		9305.1010.4	9306.1010.4
l = 7 m		9305.1011.4	9306.1011.4
l = 8 m		9305.1012.4	9306.1012.4
l = 0.001 - 0.999 m		9305.1030.4	9306.1030.4
l = 1.001 - 1.999 m		9305.1031.4	9306.1031.4
l = 2.001 - 2.999 m		9305.1032.4	9306.1032.4
l = 3.001 - 3.999 m		9305.1033.4	9306.1033.4
l = 4.001 - 4.999 m		9305.1034.4	9306.1034.4
l = 5.001 - 5.999 m		9305.1035.4	9306.1035.4
l = 6.001 - 6.999 m		9305.1036.4	9306.1036.4
l = 7.001 - 7.999 m		9305.1037.4	9306.1037.4

6.2 Cover

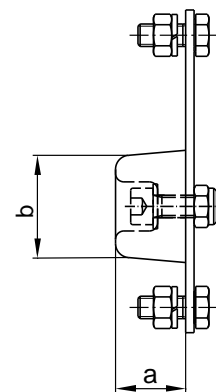

Version: Steel, galvanised.

Use: The lid serves as a profile completion. It also includes the buffer.

Profile	 [kg]	a [mm]	b [mm]		N°
GISKB I	0.400	25	40		9305.1002.4
GISKB II	0.700	25	40		9306.1002.4

6.3 Profile junction

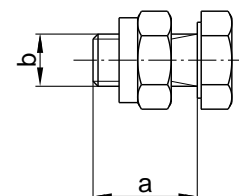

Version: Steel, galvanised.

Use: The junction of two section tracks is made by four high-tensile hexagon screws.

Profile	 [kg]	a [mm]	b		N°
GISKB I	0.100	25	M 8		9305.1003.4
GISKB II	0.200	35	M 12		9306.1003.4

6.4 Profile reinforcement

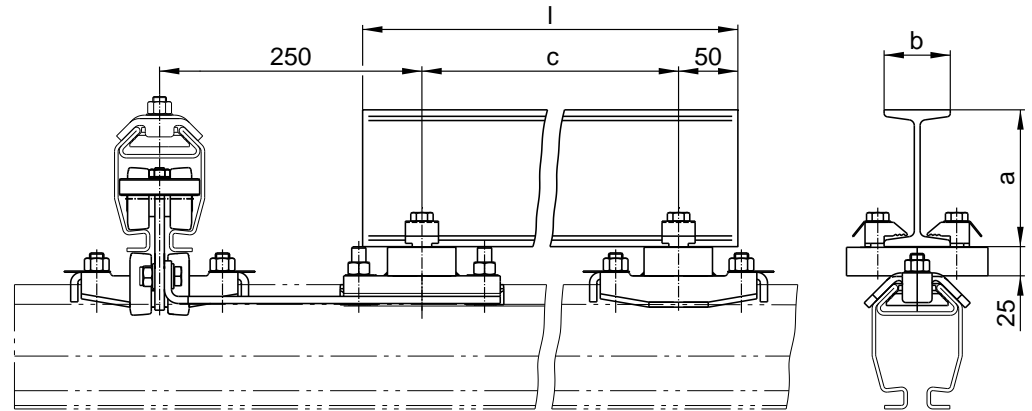

Version.....: The three varying profile reinforcements can be used for GISKB I + II. The reinforcement is primed grey and is clamped to the profile. No need of any welding.

Colour: RAL 7035 light grey.

Note: Use the clamping holder complete (see page 16) as profile junction for the necessary clamping. The length of the crane bridge span is $W - 400$ mm. IPE reinforced crane bridge to be suspended always rigid.

		IPE 120	IPE 160	IPE 180	
	[kg/m]	10.400	15.800	18.800	
a	[mm]	120	160	180	
b	[mm]	64	82	91	
c	[mm]	max. 1250	max. 1250	max. 1250	
GISKB I	W_x	[mm ³ x 10 ³]	94.66	136.04	161.14
	I_x	[mm ⁴ x 10 ⁶]	8.561	14.846	19.063
GISKB II	W_x	[mm ³ x 10 ³]	123.95	185.11	214.98
	I_x	[mm ⁴ x 10 ⁶]	13.301	21.820	27.329
l = 0 - 2 m		9309.3072.4	9309.3079.4	9309.3086.4	
l = 2 - 3 m		9309.3073.4	9309.3080.4	9309.3087.4	
l = 3 - 4 m		9309.3074.4	9309.3081.4	9309.3088.4	
l = 4 - 5 m		9309.3075.4	9309.3082.4	9309.3089.4	
l = 5 - 6 m		9309.3076.4	9309.3083.4	9309.3090.4	
l = 6 - 7 m		9309.3077.4	9309.3084.4	9309.3091.4	
l = 7 - 8 m		9309.3078.4	9309.3085.4	9309.3092.4	

Reinforcements are not available from stock.

6.5 Clamping holder complete

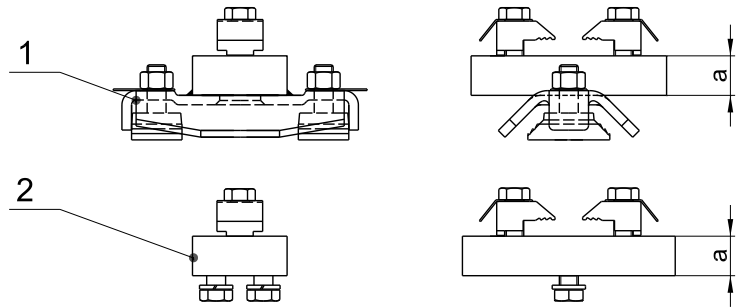

Version.....: Steel, galvanised.

Use.....: The clamping holder (Item 1) is used for connection of profile and reinforcement. The clamping holder (Item 2) must be fitted in the reinforcement of rolling apparatus (see page 22).

Item	Profile	 [kg]	a [mm]	Designation	N°
1	GISKB I + II	2.800	25	Clamping holder profile reinforcement	9309.3031.4
2	GISKB I + II	1.900	25	Clamping holder reinforcement of rolling apparatus	9309.3136.4

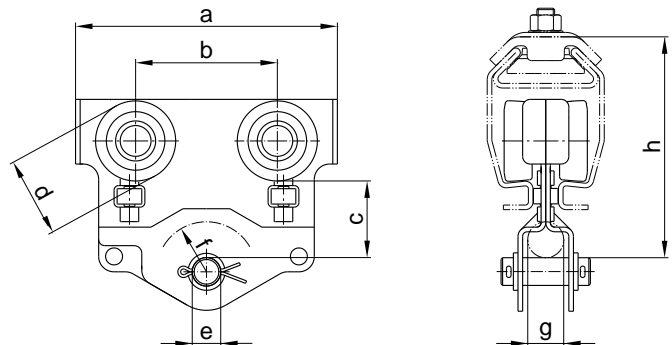

6.6 Trolley



Version.....: Steel, galvanised.

The trolley is made of steel and equipped with plastic guide rollers.

Use.....: The trolley is used as a trailer of the electric chain hoist and can be used in pendulating version as longitudinal trolley for the crane bridge.

Profile	 [kg]	 [kg]	a [mm]	b [mm]	c [mm]	d [mm]	e [mm]	f [mm]	g [mm]	h [mm]	N°
GISKB I	1.500	400	170	92	50	52	18	-	30	143	9305.1020.3
GISKB II	2.000	800	192	92	62	74	18	-	30	181	9306.1020.3

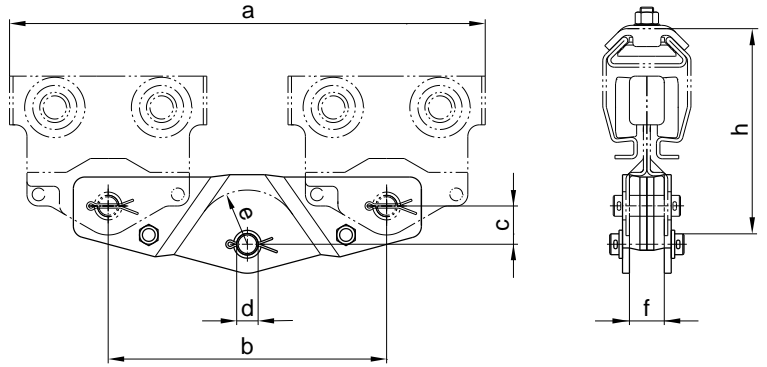

A traverse is coupled with two trolleys so as to favour the load partition. The saddle of the double crane bridge (see page 17) requires four trolleys.

6.7 Traverse



Version:.....Steel, galvanised.

Use:.....The traverse allows a coupling of two trolleys.

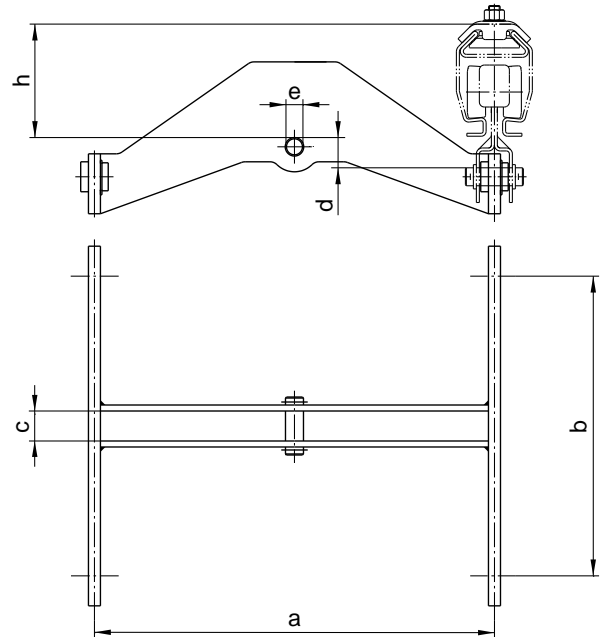

Profile	 [kg]	 [kg]	a [mm]	b [mm]	c [mm]	d [mm]	e [mm]	f [mm]	h [mm]		N°
GISKB I	2.000	800	410	240	33	18	-	30	176		9309.3020.3
GISKB II	2.000	1600	432	240	33	18	-	30	214		9309.3020.3

6.8 Saddle



Version.....: Steel, galvanised.

Use.....: The saddle allows the junction of four trolleys for the double crane bridge version.

Profile	 [kg]	 [kg]	a [mm]	b [mm]	c [mm]	d [mm]	e [mm]	h [mm]		N°
GISKB I	7.100	1600	400	300	30	30	18	113		9309.3021.3
GISKB II	7.100	1600	400	300	30	30	18	151		9309.3021.3

6.9 Overview crane bridge suspension

6.9.1 Simple crane bridge pendulating

Crane track: GISKB I / GISKB II, Crane bridge: GISKB I / GISKB II

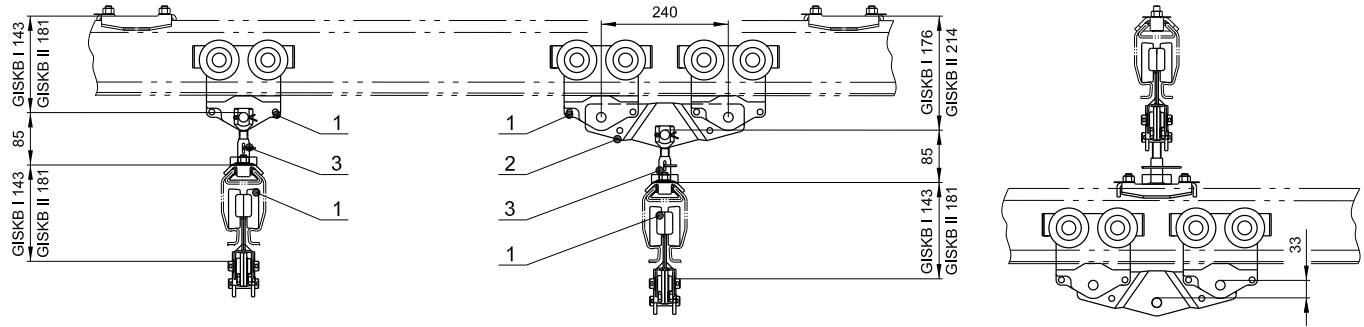

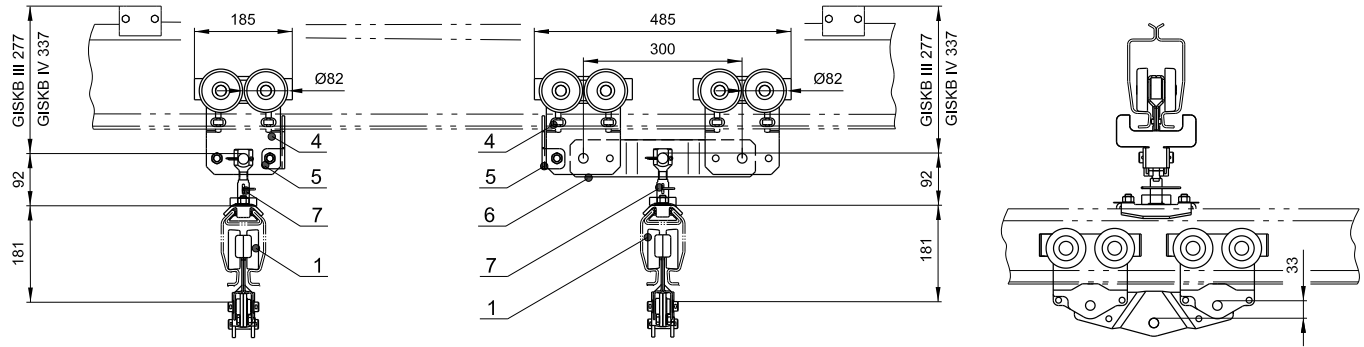

Crane track: GISKB III / GISKB IV, Crane bridge: GISKB II

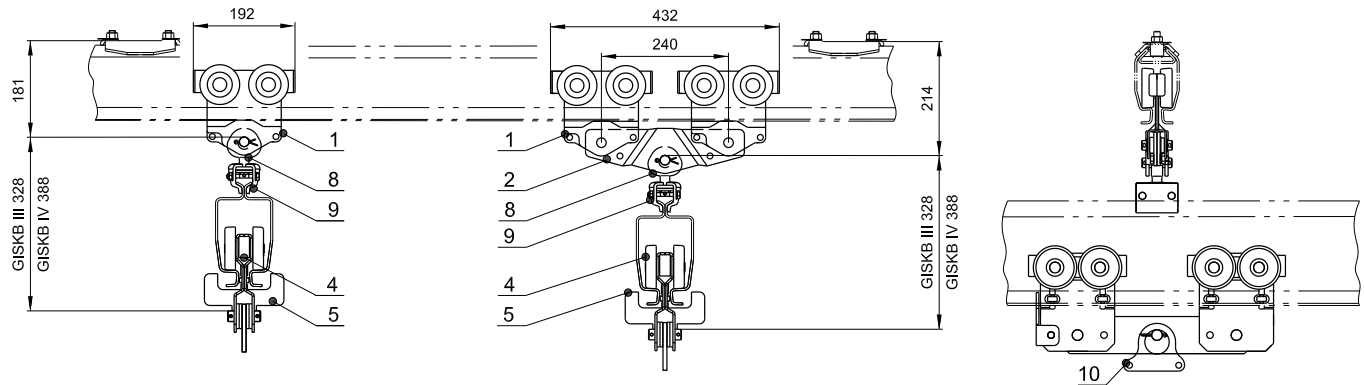

Crane track: GISKB II, Crane bridge: GISKB III / GISKB IV



Item	Profile	 [kg]	 [kg]	Designation	N°
1	GISKB I	1.500	400	Trolley	9305.1020.3
	GISKB II	2.000	800	Trolley	9306.1020.3
2	GISKB I + II	2.000	1600	Traverse	9309.3020.3
3	GISKB I + II	1.600	1600	Crane bridge suspended pendulating	9309.3068.4
4	GISKB III + IV	6.200	800	Trolley	9307.1002.3
5	GISKB III + IV	0.500	1600	Overload protection	9307.1108.4
6	GISKB III + IV	3.400	1600	Traverse	9307.1006.3
7	GISKB III + IV	1.200	1600	Crane bridge suspension	9307.1050.4
8	GISKB III + IV	0.600	1600	Articulated suspension	9307.1003.4
9	GISKB III + IV	0.400	1600	Profile retainer complete	9307.1004.4
10	GISKB III + IV	0.600	1000	Eyebolt suspension GCH 250/500	9307.1052.4
	GISKB III + IV	1.100	1600	Eyebolt suspension GCH 1000	9307.1049.4

6.9.2 Single crane bridge rigid

Crane track: GISKB I / GISKB II, Crane bridge GISKB I / GISKB II

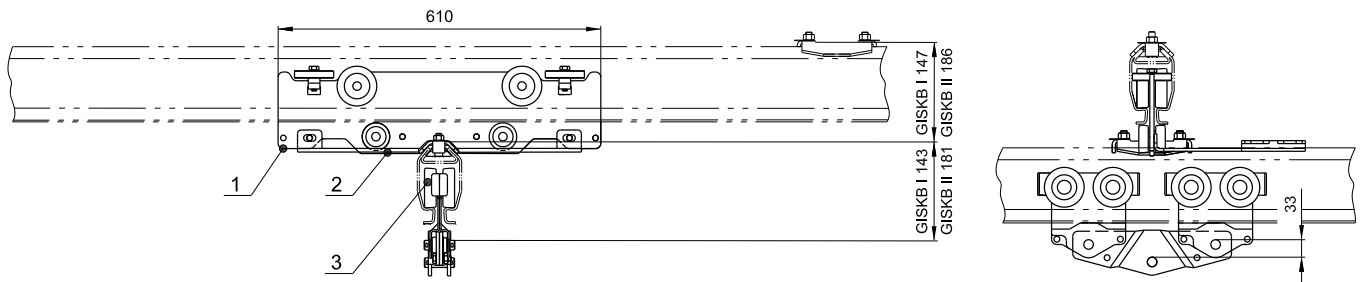

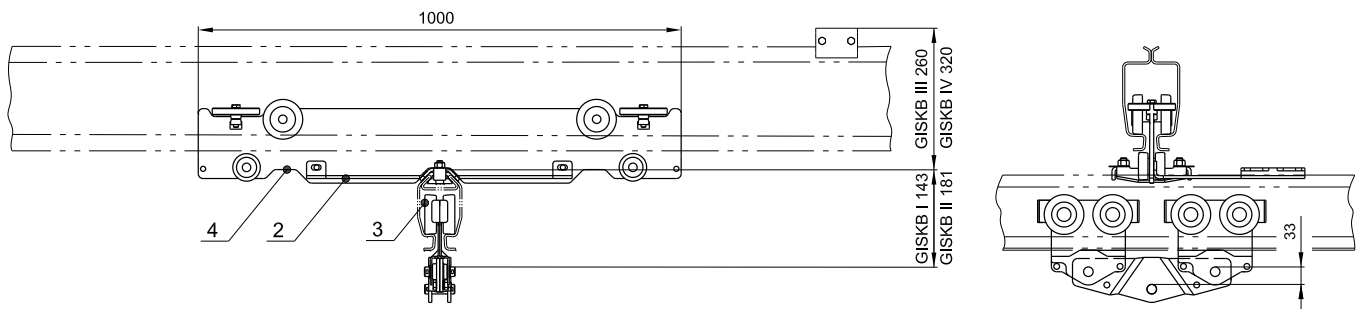

Crane track: GISKB III / GISKB IV, Crane bridge: GISKB I / GISKB II

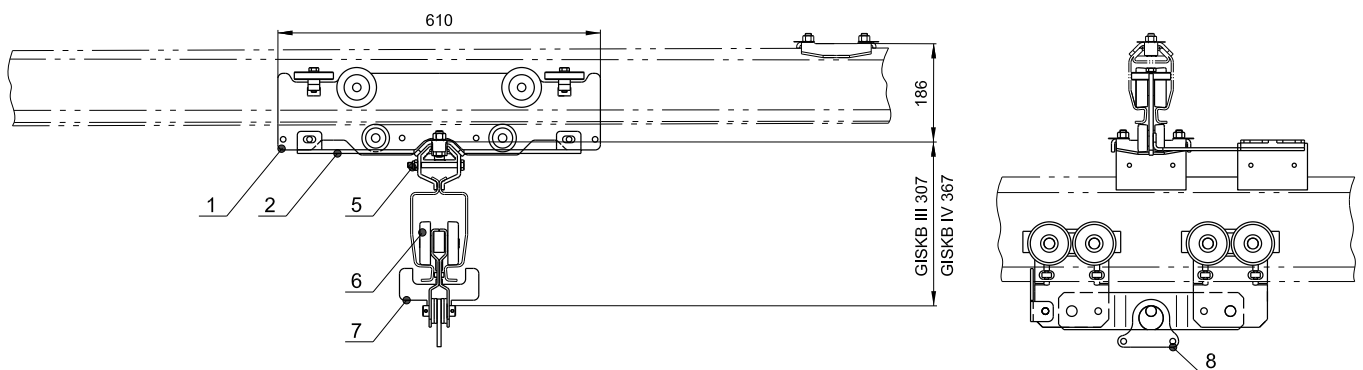

Crane track: GISKB II, Crane bridge: GISKB III / GISKB IV



Item	Profile	 [kg]	 [kg]	Designation	N°
1	GISKB I	5.500	800	Rolling apparatus EQB	9305.1022.3
	GISKB II	6.500	1600	Rolling apparatus EQB	9306.1022.3
2	GISKB I + II	3.000	1600	Reinforcement of rolling apparatus	9309.3135.3
3	GISKB I	1.500	400	Trolley	9305.1020.3
	GISKB II	2.000	800	Trolley	9306.1020.3
4	GISKB III + IV	14.000	1600	Rolling apparatus EQB	9307.1118.3
5	GISKB III + IV	0.500	1600	Profile retainer complete	9307.1055.3
6	GISKB III + IV	6.200	800	Trolley	9307.1002.3
7	GISKB III + IV	0.500	1600	Overload protection	9307.1108.4
8	GISKB III + IV	0.600	1000	Eyebolt suspension GCH 250/500	9307.1052.4
	GISKB III + IV	1.100	1600	Eyebolt suspension GCH 1000	9307.1049.4

6.9.3 Double crane bridge rigid

Crane track: GISKB I / GISKB II, Crane bridge GISKB I / GISKB II

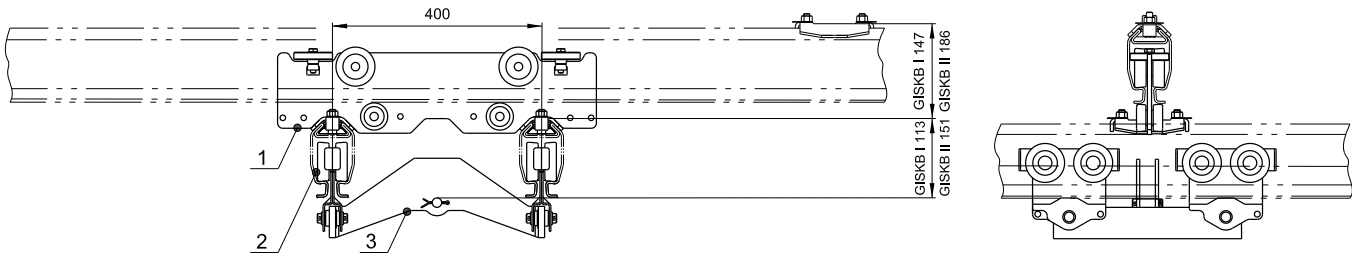

Crane track: GISKB III / GISKB IV, Crane bridge: GISKB II

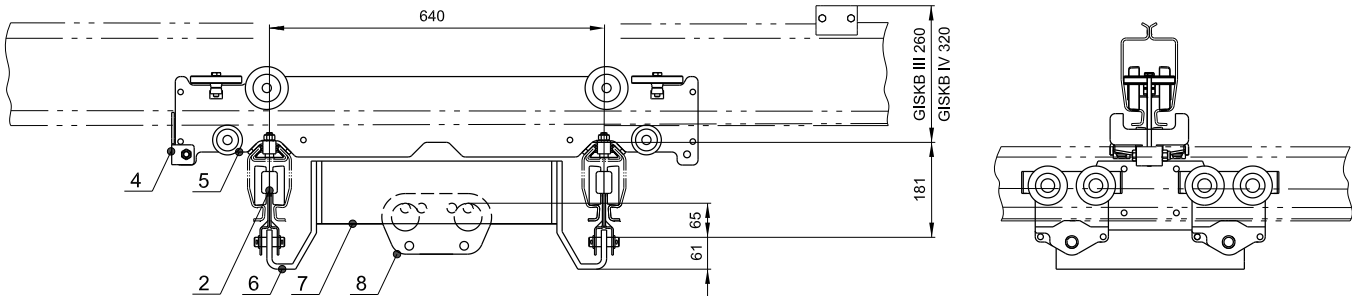

Crane track: GISKB II, Crane bridge: GISKB III / GISKB IV

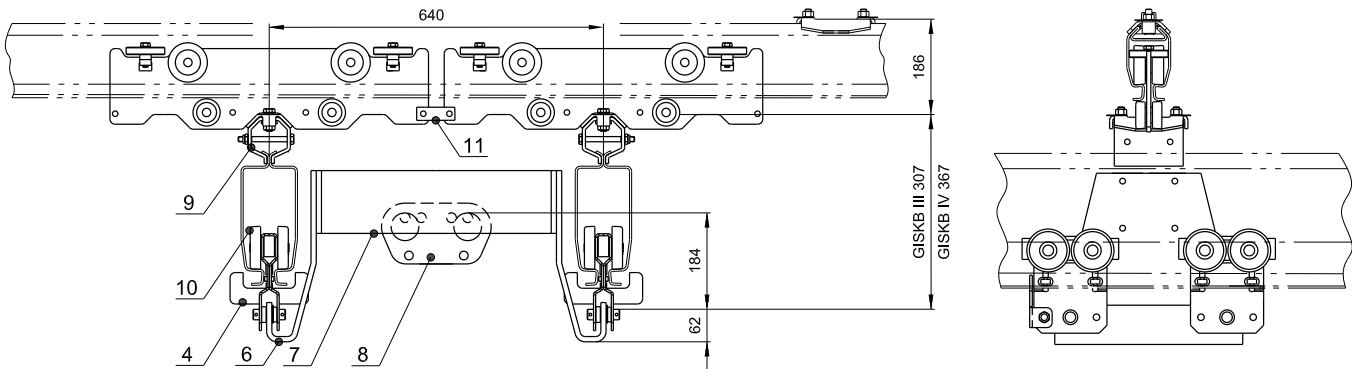

Item	Profile	 [kg]	 [kg]	Designation	N°
1	GISKB I	6.000	800	Rolling apparatus DQB	9305.1023.3
	GISKB II	7.000	1600	Rolling apparatus DQB	9306.1023.3
2	GISKB I	1.500	400	Trolley	9305.1020.3
	GISKB II	2.000	800	Trolley	9306.1020.3
3	GISKB I + II	7.100	1600	Saddle	9309.3021.3
4	GISKB III + IV	0.500	1600	Overload protection	9307.1108.4
5	GISKB III + IV	14.000	1600	Rolling apparatus DQB	9307.1118.3
6	GISKB III + IV	5.900	1600	Bracket saddle	9307.1100.3
	GISKB III + IV	8.800	1600	Bracket saddle above	9307.1101.3
7	GISKB III + IV	11.000	1600	Traverse saddle	9307.1104.3
8	GISKB III + IV	0.800	1000	Suspension part GCH 250/500	9401.3046.4
	GISKB III + IV	2.000	1600	Suspension part GCH 1000	9307.1103.3
	GISKB III + IV	2.800	1600	Suspension part GCH 1600/2000/2500	9408.3020.3
9	GISKB III + IV	0.500	1600	Profile retainer complete	9307.1055.3
10	GISKB III + IV	6.200	800	Trolley	9307.1002.3
11	GISKB I + II	0.200	1600	Connector rolling apparatus complete	9307.1107.4

6.10 Crane bridge suspension pendulating

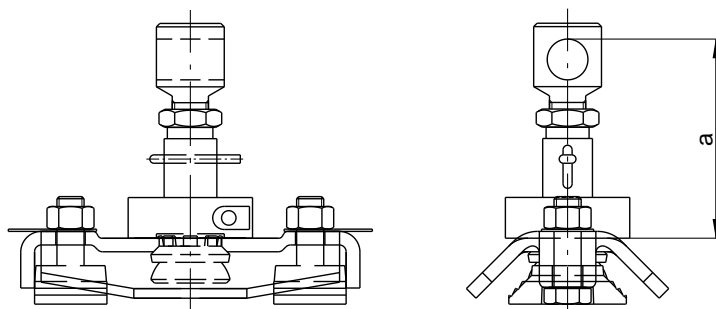

Version.....: Steel, galvanised.

Use.....: For pendulating suspension of the crane bridge.

Note: A pendulating suspended crane bridge is only possible with pendulating crane track.

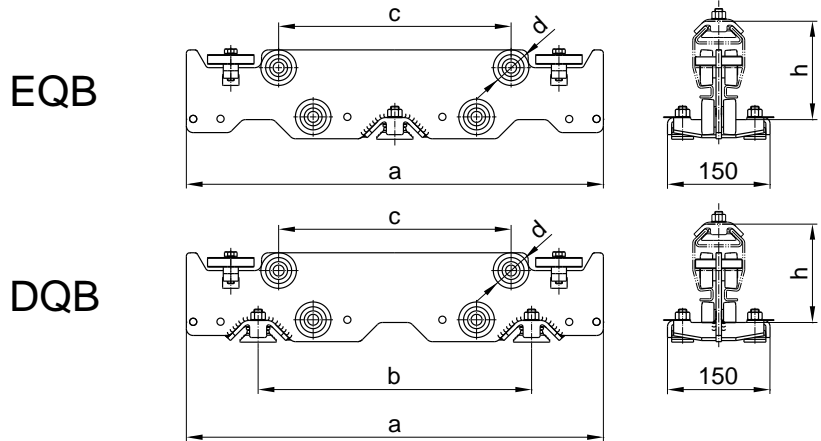

Profile	 [kg]	 [kg]	a [mm]		N°
GISKB I + II	1.600	1600	85		9309.3068.4

6.11 Rolling apparatus



Version: Steel, galvanised. The rolling apparatus is equipped with plastic rollers. Lateral guide rollers and counter-pressure rollers prevent tipping up in profile.

Use: The EQB version is used for single crane bridges, the DQB version for double crane bridges. The crane bridge is secured in two versions. The crane track can be mounted pendulated or rigidly.

Profile	 [kg]	 [kg]	a [mm]	b [mm]	c [mm]	d [mm]	h [mm]		N°
GISKB I EQB	5.500	800	610	-	340	52	147		9305.1022.3
GISKB I DQB	6.000	800	610	400	340	52	147		9305.1023.3
GISKB II EQB	6.500	1600	610	-	312	74	186		9306.1022.3
GISKB II DQB	7.000	1600	610	400	312	74	186		9306.1023.3

6.12 Reinforcement of rolling apparatus

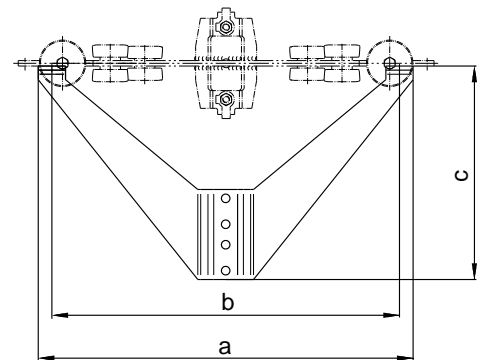

Version: Steel, galvanised. The reinforcement stabilises the connection from the crane bridge to the rolling apparatus, thereby improving the running property.

Use: The reinforcements always used when using EQB rolling apparatus devices.

Profile	 [kg]	a [mm]	b [mm]	c [mm]		N°
GISKB I + II	3.000	550	510	313		9309.3135.3

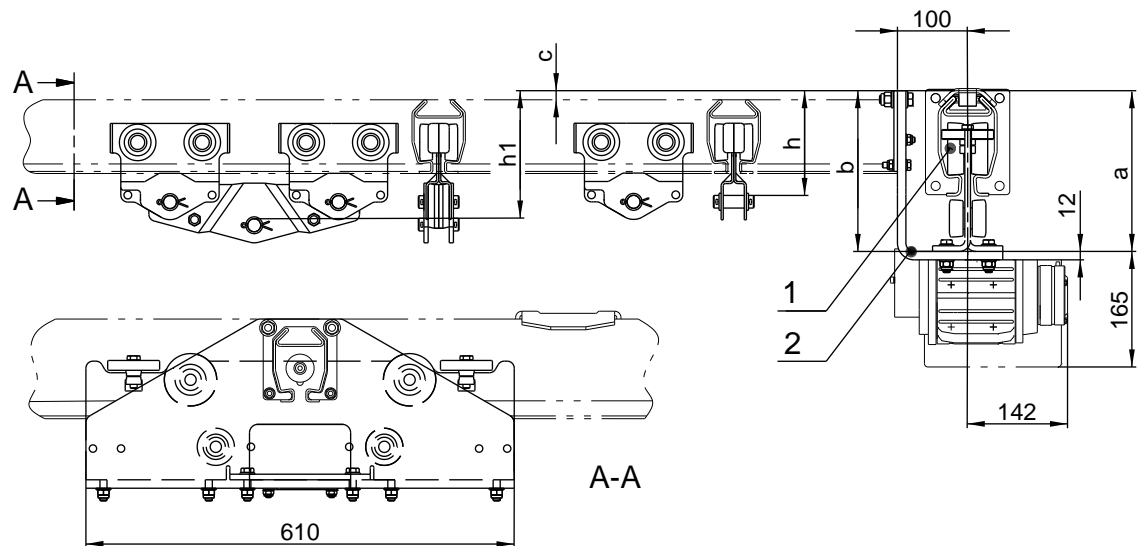

6.13 Breaker





Version.....: Steel, galvanised.

Use.....: Connection of roller apparatus and crane bridge. The crane bridge is mounted between the crane tracks. Thereby, the overall height is considerably reduced.

Rolling apparatus (Item 1)

Profile	 [kg]	 [kg]	N°
GISKB I	8.400	800	9309.3184.2
GISKB II	9.800	1600	9309.3186.2
GISKB III + IV	19.600	1600	9309.3188.2

Bracket (Item 2)

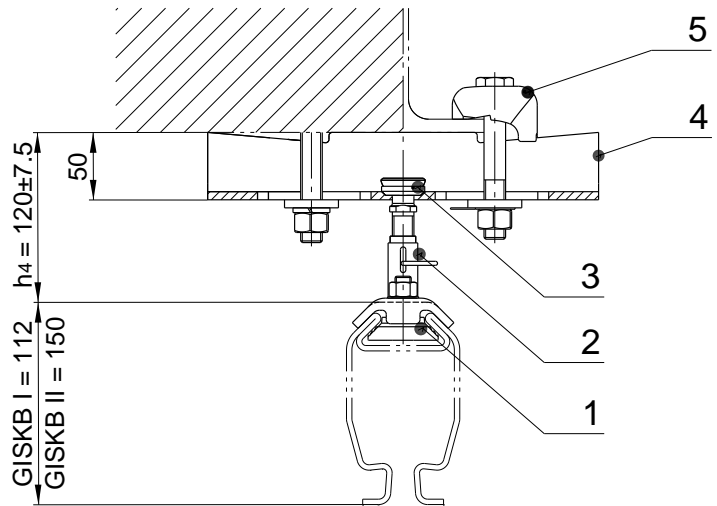

Crane track	Crane bridge	 [kg]	 [kg]	a [mm]	b [mm]	c [mm]	h [mm]	h1 [mm]	N°
GISKB I	GISKB I EQB	14.200	800	190	190	13	150	183	9309.3150.2
	GISKB I DQB	16.300	800	190	190	13	117	-	9309.3166.2
	GISKB II EQB	14.200	800	190	190	13	186	219	9309.3150.2
	GISKB II DQB	16.300	800	190	190	13	153	-	9309.3166.2
GISKB II	GISKB I EQB	15.000	800	229	229	13	150	183	9309.3152.2
	GISKB I DQB	17.800	800	229	229	13	117	-	9309.3168.2
	GISKB II EQB	15.000	1600	229	229	13	186	219	9309.3152.2
	GISKB II DQB	17.800	1600	229	229	13	153	-	9309.3168.2
GISKB III	GISKB I EQB	14.200	800	303	269	13	184	217	9309.3154.2
	GISKB I DQB	16.300	800	303	269	13	157	-	9309.3170.2
	GISKB II EQB	14.200	1600	303	269	13	220	253	9309.3154.2
	GISKB II DQB	16.300	1600	303	269	13	193	-	9309.3170.2
GISKB IV	GISKB I EQB	14.200	800	363	329	13	184	217	9309.3156.2
	GISKB I DQB	16.300	800	363	329	13	157	-	9309.3172.2
	GISKB II EQB	14.200	1600	363	329	13	220	253	9309.3156.2
	GISKB II DQB	16.300	1600	363	329	13	193	-	9309.3172.2

6.14 Suspension pendulating short adjustable



Version.....: Steel, galvanised. Ball pin (3) and ball nut (2) are screwed directly together to form the shortest pendulating suspension. Pendulating movements of max. 10° are permissible. The suspension can be adjusted by ± 7.5 mm.

Note.....: Please consider the guidelines for suspensions (see page 7).

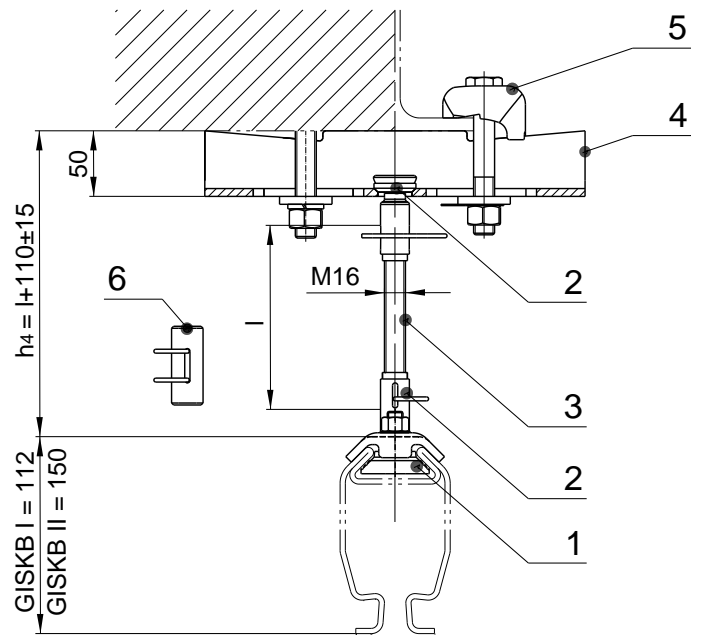

Item	 [kg]	 [kg]	Designation	N°
1	0.800	1600	Profile retainer complete	9309.3032.4
2	0.160	1600	Ball nut complete	9309.3011.4
3	0.120	1600	Ball pin complete	9309.3010.4
4	2.000	1600	Ceiling clip	9309.3003.3
5	0.600	800	Binding clip complete	9309.3005.4

6.15 Suspension pendulating distanced adjustable



Version.....: Steel, galvanised. The threaded rod (3) which is variable in length forms with two screwed ball nuts (2) the distanced suspension. With the suspension height differences of ± 15 mm can be adjusted. With the coupling (6), two threaded rods can be connected. A suspension can consist of several threaded rods. For special lengths of the threaded rods, make sure that the hole for mechanical locking is available.

Note: For distanced suspensions greater than or equal to $h_4 = 500$ mm (see page 10) bracings are provided. Please consider the guidelines for suspensions (see page 7).

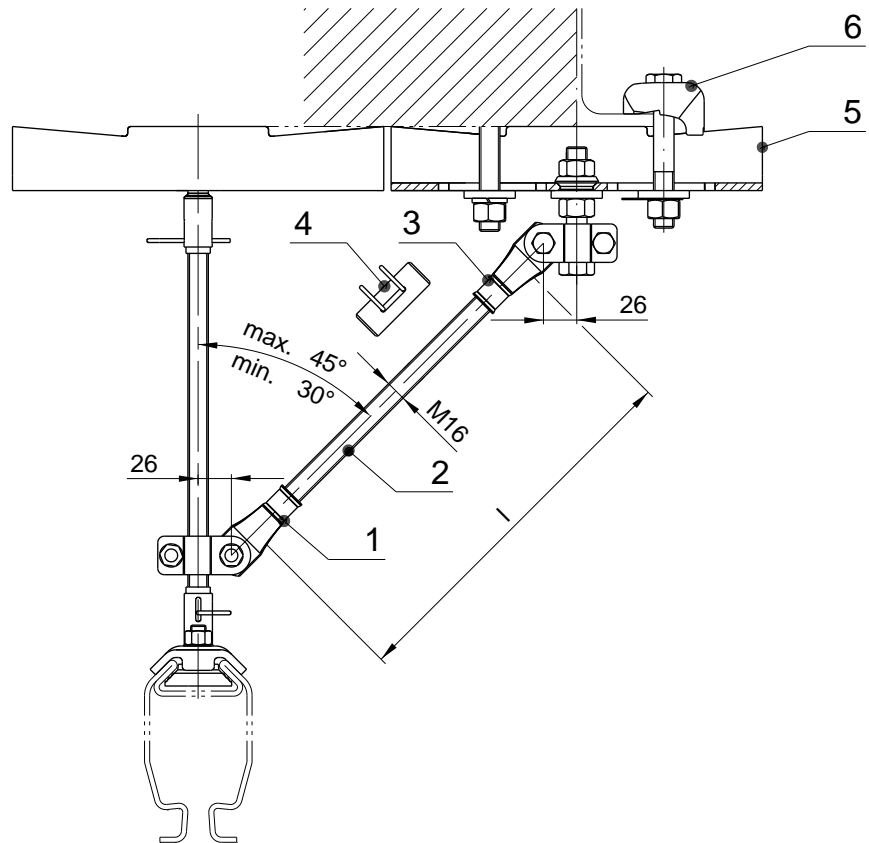

Item	 [kg]	 [kg]	Designation	N°
1	0.800	1600	Profile retainer complete	9309.3032.4
2	0.160	1600	Ball nut complete	9309.3011.4
3	0.100	1600	Threaded rod, l = 100 mm	9309.3024.4
	0.200	1600	Threaded rod, l = 200 mm	9309.3025.4
	0.400	1600	Threaded rod, l = 300 mm	9309.3026.4
	0.650	1600	Threaded rod, l = 500 mm	9309.3027.4
	1.200	1600	Threaded rod, l = 1000 mm	9309.3028.4
4	2.000	1600	Ceiling clip	9309.3003.3
5	0.600	800	Binding clip complete	9309.3005.4
6	0.150	1600	Coupling complete	9309.3033.4

6.16 Bracing pendulating distanced adjustable



Version: Steel, galvanised. The bracing is composed of the knots below (1) and the knots above (3) connected to a threaded rod (2). The length of the threaded rod is the same as for the suspension.

Note.....: Please consider the guidelines for suspensions (see page 7).

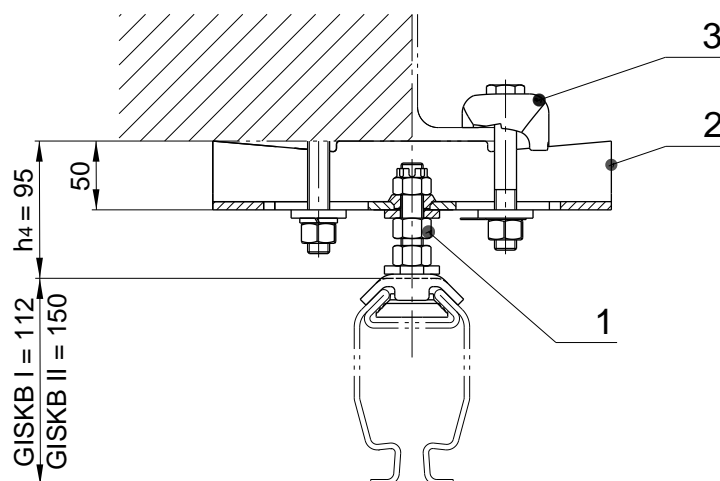

Item	 [kg]	 [kg]	Designation	N°
1	0.300	1600	Lower knots	9309.3015.4
2	0.100	1600	Threaded rod, l = 100 mm	9309.3024.4
	0.200	1600	Threaded rod, l = 200 mm	9309.3025.4
	0.400	1600	Threaded rod, l = 300 mm	9309.3026.4
	0.650	1600	Threaded rod, l = 500 mm	9309.3027.4
	1.200	1600	Threaded rod, l = 1000 mm	9309.3028.4
3	0.600	1600	Upper knots	9309.3016.4
4	0.150	1600	Coupling complete	9309.3033.4
5	2.000	1600	Ceiling clip	9309.3003.3
6	0.600	800	Binding clip complete	9309.3005.4

6.17 Suspension rigid direct



Version.....: Steel, galvanised.

Note: The rigid suspension is available only as a short version. Please consider the guidelines for suspensions (see page 7). This suspension is not adjustable in height.

Item	 [kg]	 [kg]	Designation	N°
1	1.250	1600	Suspension rigid	9309.3013.4
2	2.000	1600	Ceiling clip	9309.3003.3
3	0.600	800	Binding clip complete	9309.3005.4

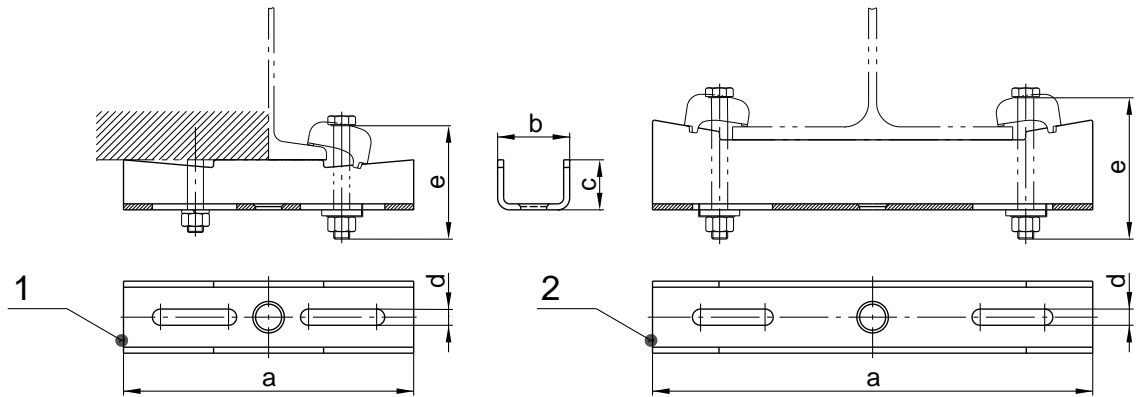

6.18 Ceiling clip



Version.....: Steel, galvanised.

Use.....: Suspension on steel construction (Item 1, Item 2) and flat concrete ceiling (Item 1).

Note.....: Fixing material for flat concrete ceilings is not delivered by us: Please contact specialised dealer. The ceiling clip (Item 2) is not suitable for assembly on to flat concrete ceilings.

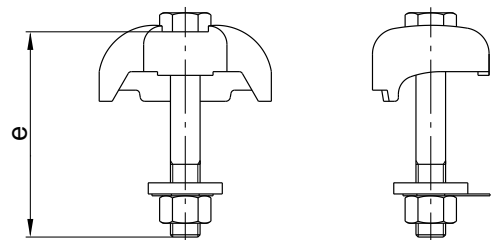

Item	Profile	 [kg]	 [kg]	 [mm]	a [mm]	b [mm]	c [mm]	d [mm]	e [mm]	N°
1	GISKB I + II	2.000	1600	65 - 200	290	72	50	16.2	110	9309.3003.3
2	GISKB I + II	4.000	1600	200 - 300	440	72	70	16.2	150	9309.3112.3

6.19 Binding clip complete



Version.....: Steel, galvanised.

Use.....: Suspension on steel structure.

Profile	 [kg]	 [kg]	e [mm]	Designation	N°
GISKB I + II	0.600	800	110	Binding clip compl. ceiling clip 65-200 mm	9309.3005.4
GISKB I + II	0.650	800	150	Binding clip compl. ceiling clip 200-300 mm	9309.3113.4

6.20 Support to ceiling clip

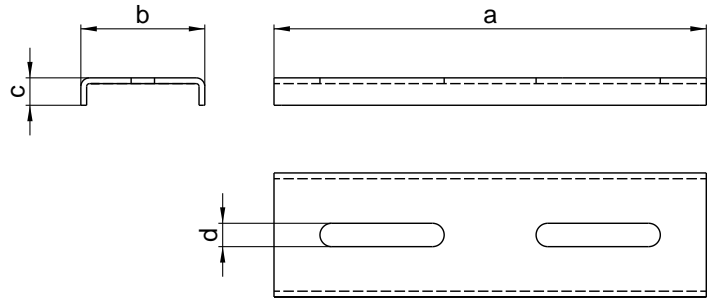

Version.....: Steel, galvanised.

Use.....: Suspension on flat concrete ceiling or on concrete ceiling with cast-in steel rails (Halfen, Jordal).

Profile	 [kg]	a [mm]	b [mm]	c [mm]	d [mm]		N°
GISKB I + II	1.000	300	86	19	16.2		9309.3115.3

6.21 Lateral suspension

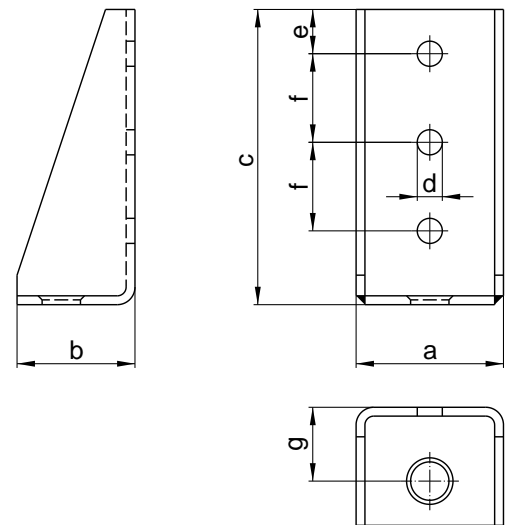

Version.....: Steel, galvanised.

Use.....: Lateral suspension to wooden truss or concrete applications. The suspension is suitable for the rigid and pendulating version.

Note: Fixing material is not delivered by us: Please contact specialised dealer.

Profile	 [kg]	a [mm]	b [mm]	c [mm]	d [mm]	e [mm]	f [mm]	g [mm]		N°
GISKB I + II	2.000	100	80	200	17	30	60	50		9309.3111.3

6.22 GIS adhesive

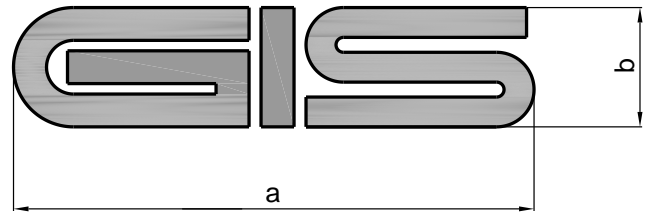

Version: Grey, self-adhesive.

Use: Crane bridge, monorail.

Type	Profile	a [mm]	b [mm]		N°
Small	GISKB I + II	174	40		9309.5075.4

6.23 Lifting capacity adhesive

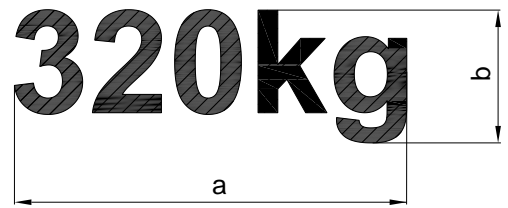

Version: Black, self-adhesive.

Use: Crane bridge, monorail.

Type	Profile	 [kg]	a [mm]	b [mm]		N°
Small	GISKB I + II	80	100	40		9309.5080.4
	GISKB I + II	100	125	40		9309.5081.4
	GISKB I + II	125	125	40		9309.5082.4
	GISKB I + II	160	125	40		9309.5083.4
	GISKB I + II	200	125	40		9309.5084.4
	GISKB I + II	250	125	40		9309.5085.4
	GISKB I + II	320	125	40		9309.5086.4
	GISKB I + II	400	125	40		9309.5087.4
	GISKB I + II	500	125	40		9309.5088.4
	GISKB I + II	630	125	40		9309.5089.4
	GISKB I + II	800	125	40		9309.5090.4
	GISKB I + II	1000	150	40		9309.5091.4
	GISKB I + II	1250	150	40		9309.5092.4
GISKB I + II	1600	150	40		9309.5093.4	

6.24 Electric tug

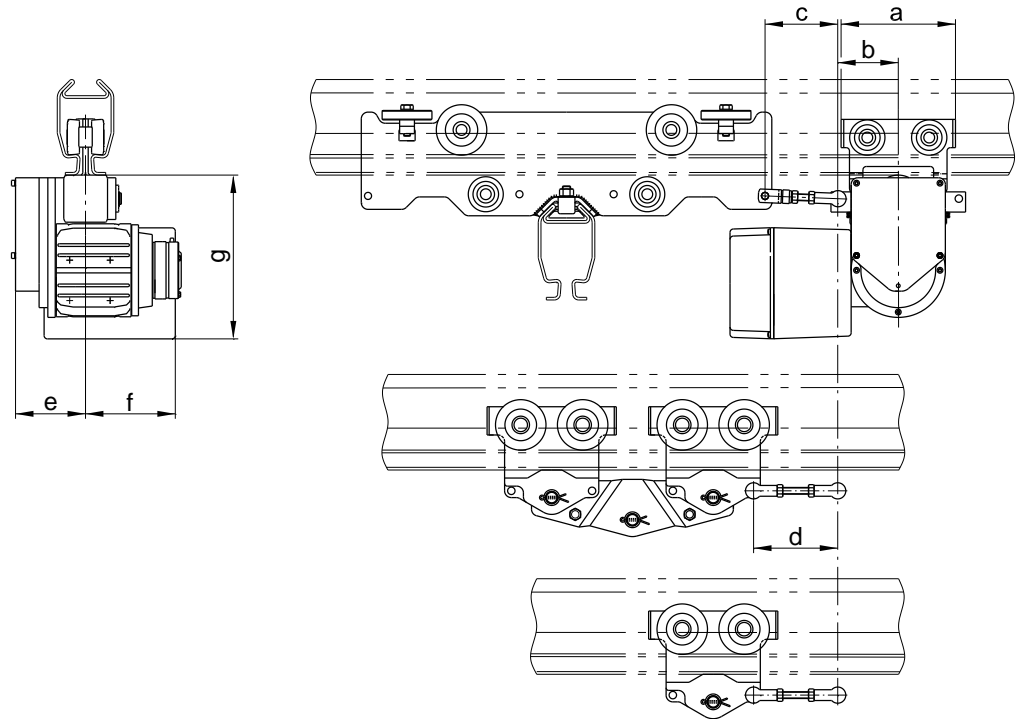

Version.....: Friction roller drive. Trolley galvanised and equipped with plastic rollers, gear housing and motor in black finish. Controlled by frequency converter (FU) and equipped with brake as standard.

Use.....: Electric drive for cross and long travel in GISKB I + II.

Note: Connector clamp to trolley and rolling apparatus have to be ordered separately. When the crane bridge is moved electrically, a rigid crane bridge suspension must always be selected (see page 19 - 20).

Profile	 [kg]	a [mm]	b [mm]	c [mm]	d [mm]	e [mm]	f [mm]	g [mm]	N°
GISKB I	15.100	170	90	100	125	104	134	244	SAKB1.BR/FU
GISKB I	14.600	170	90	100	125	104	134	244	SAKB1.BR
GISKB II	15.100	170	90	100	125	104	134	244	SAKB2.BR/FU
GISKB II	14.600	170	90	100	125	104	134	244	SAKB2.BR

Type specification and technical data:

Type	Profile	 [kg]	Speed [m/min]	Power [kW]	3 x 400 V 50 Hz [A]	%duty / S/h	Version
SAKB.BR/FU	GISKB I + II	800	3-12 / 3-35	0.25	0.8	60 / 360	with control
SAKB.BR	GISKB I + II	800	3-12 / 3-35	0.25	0.8	60 / 360	without control

A single electric tug can move loads up to 1600 kg if used for a monorail.

The ramps and speeds are factory-set (6/35 m/min). However, these can be customised by trained personnel. The adjustable frequency is min. 8 Hz (3 m/min) to max. 87 Hz (35 m/min).

The electric tug is available for the following operating voltages: 400-480 V 50/60 Hz, 208-240 V 50/60 Hz, 500-575 V 50/60 Hz.

6.25 Connector clamp trolley

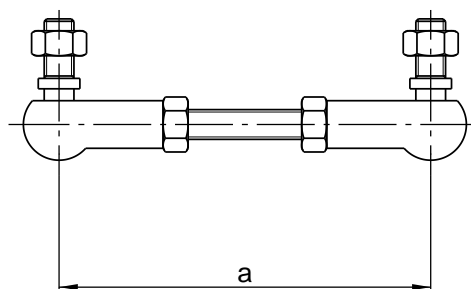

Version.....: Steel, galvanised.

Use.....: Connection of electric tug and trolley.

Profile	 [kg]	a [mm]	N°
GISKB I + II	0.200	125	9310.5011.4

6.26 Connection clamp rolling apparatus

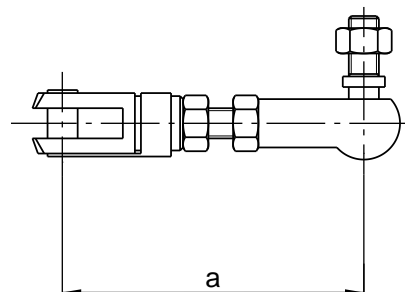

Version.....: Steel, galvanised.

Use.....: Connection of electric tug and rolling apparatus.

Profile	 [kg]	a [mm]	N°
GISKB I + II	0.200	100	9310.5012.4

6.27 Bend

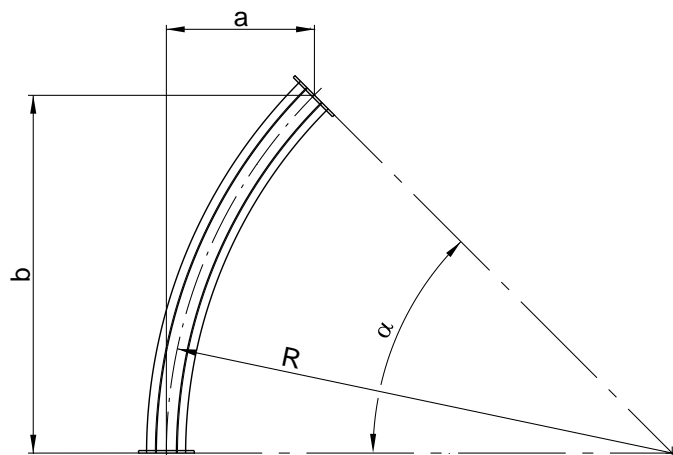

Version.....: The bends are available with 30° and 45° angles. The radius is always 1000 mm. is welded one each end plate.

Colour: RAL 7035 light grey.

Note: By assembling multiple bend segments different angles can be created (see sketch).

Guide notes for the suspension points

The suspension of the bends can be of pendulating short type, pendulating rod and rigid type. Bends of pendulating rod suspension type must be braced longitudinally and laterally, whilst the lateral bracing must show towards the interior side of the bend. The segment of the bend must be suspended twice (see sketch).

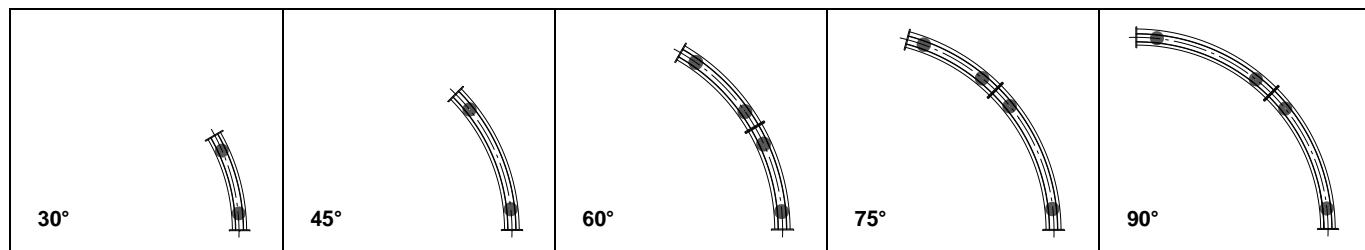

Profile	 [kg]	α	R [mm]	a [mm]	b [mm]		N°
GISKB I	5.240	30°	1000	134	500		9305.1024.4
GISKB I	7.860	45°	1000	293	707		9305.1025.4
GISKB II	8.380	30°	1000	134	500		9306.1026.4
GISKB II	12.570	45°	1000	293	707		9306.1027.4

6.28 Conductor line VA24, 4-poles, bend

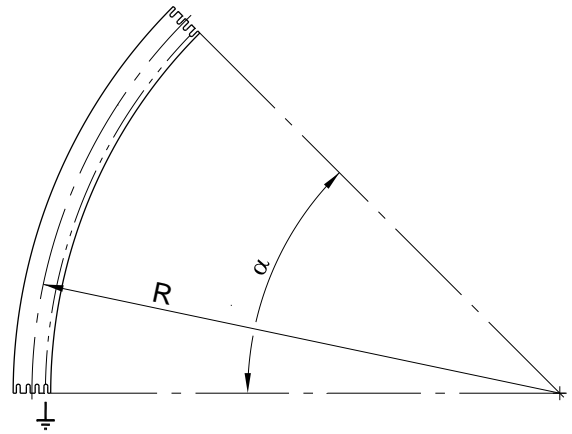

Version: Conductor line curves are available at the same angles as the bend of the profile. There are versions with radius 900 mm (mounting inside) and radius 1100 mm (installation outside). In addition the position of the earth wire must be defined.

Guide notes for the suspension points

Each bend must be suspended twice as a minimum.

Type	 [kg]	α	R [mm]	Grounding conductor		N°
30° / 900 / PE r	0.520	30°	900	right		9309.3096.4
30° / 900 / PE l	0.520	30°	900	left		9309.3097.4
30° / 1100 / PE r	0.640	30°	1100	right		9309.3098.4
30° / 1100 / PE l	0.640	30°	1100	left		9309.3099.4
45° / 900 / PE r	0.780	45°	900	right		9309.3100.4
45° / 900 / PE l	0.780	45°	900	left		9309.3101.4
45° / 1100 / PE r	0.950	45°	1100	right		9309.3102.4
45° / 1100 / PE l	0.950	45°	1100	left		9309.3103.4

Order example:

30° / 900 / PE r
9309.3096.4

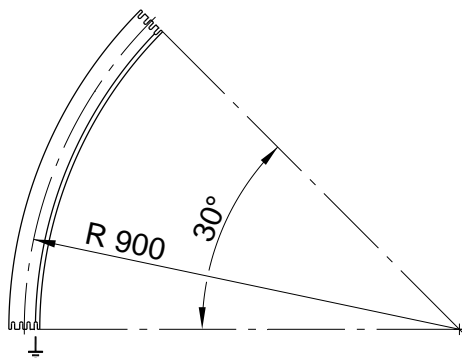

6.29 Track switch

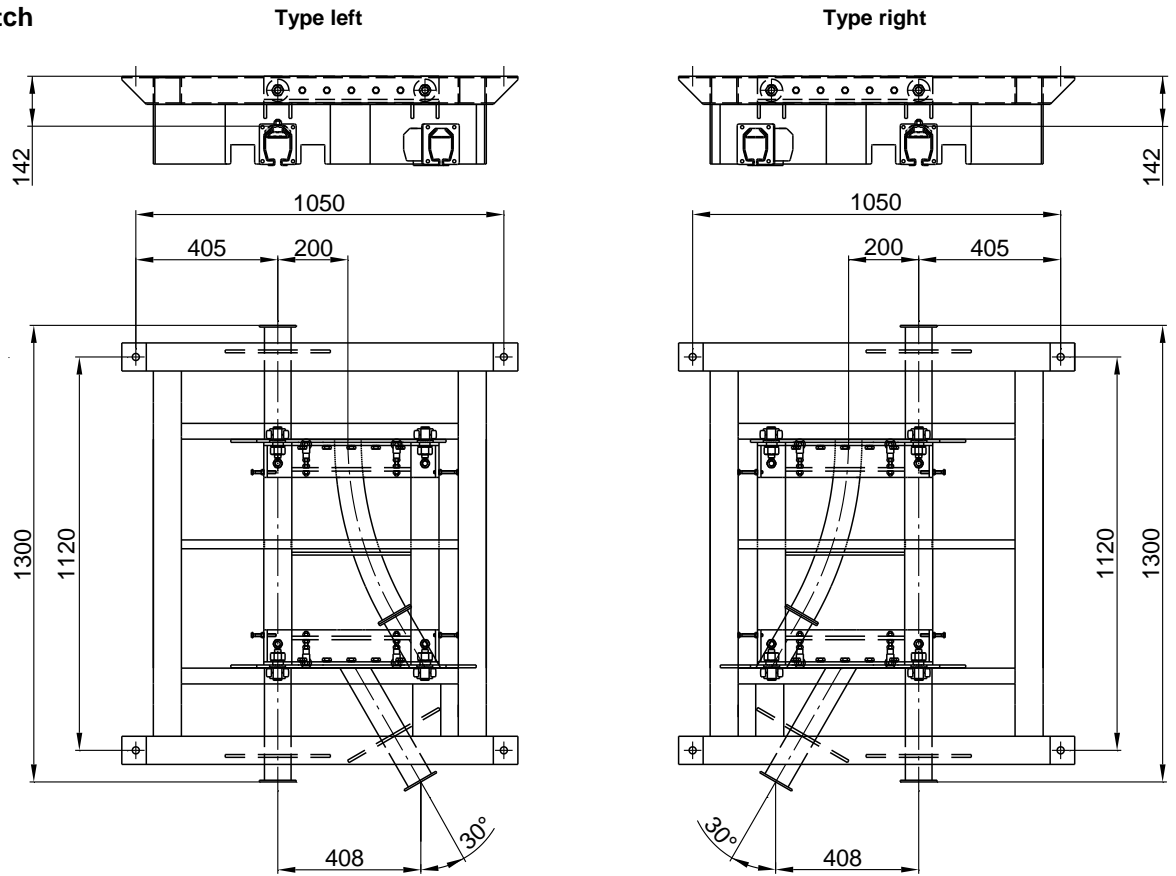

Version.....: The track switch is of sliding type. Moving the profiles is done manually or by means of electric drive (operation see page 36).

Colour: RAL 7035 light grey.

Note: For the provision of a conductor line your order must contain further details (see page 37).

Guide notes for the suspension points

The four suspension points (1120 x 1050 mm) are mounted on to the ceiling which is duly levelled. Please do pay attention to the joining profiles distance of which must be 150 mm as a minimum.

Profile	 [kg]	Type	N°
GISKB I	128.000	Track switch right	9309.3501.3
GISKB I	128.000	Track switch left	9309.3502.3
GISKB II	142.000	Track switch right	9309.3503.3
GISKB II	142.000	Track switch left	9309.3504.3

Example of order:

Track switch right 9309.3501.3, operation electrically 9309.3551.2, 3 x 400 V 50 Hz, control cable length 2 meters
 Conductor line R = 900, PE right 9309.3542.2

6.30 Operation of track switch

manually

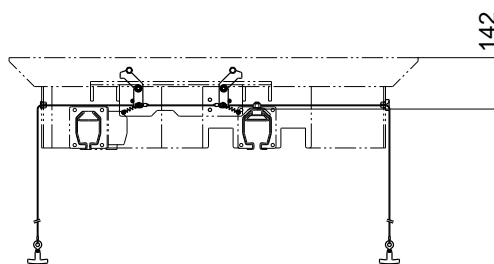

electrically (electric chain hoist)

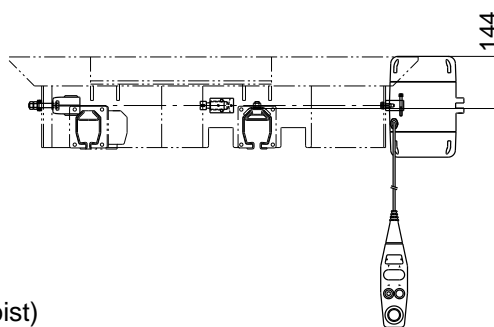

Version: In manual operation moving the profiles is done by a cable (standard length 2 m). The operation of the electric drive via a 2-button pendant control (standard control cable length 2 m).

Profile	 [kg]	Type		N°
GISKB I + II	6.000	manually		9309.3550.2
GISKB I + II	27.000	electrically		9309.3551.2

6.31 Conductor line VA24, 4-poles, track switch

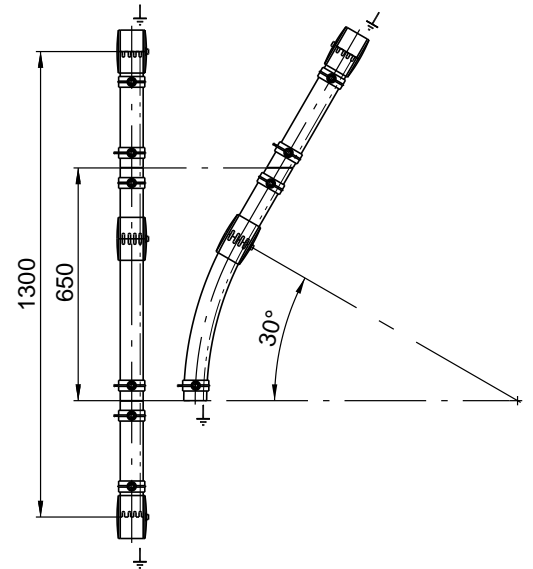

Version.....: The track switches can optionally be delivered with 4-poles conductor lines. When ordering the position of the conductor line to the profile and the position of the grounding conductor must be defined.

Note: The conductor line is assembled at the works and duly adapted. The supply of the fittings are made to the respective profile ends. The conductor line runs in the points area approximately 20 mm lower than outside the track switch. This difference in level must not be compensated when the next conductor line suspension is chosen approximately 1 m from the track switch.

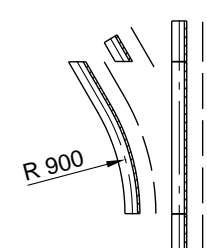
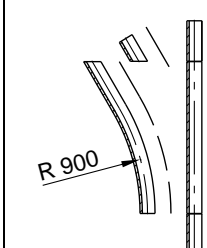
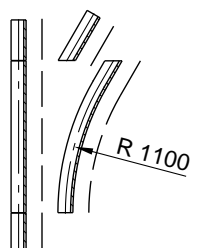
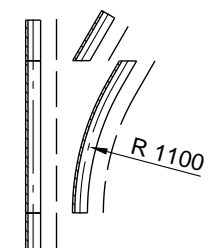
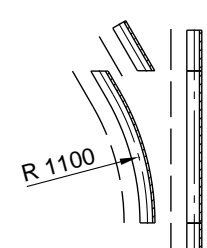
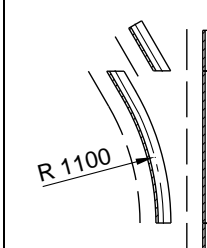
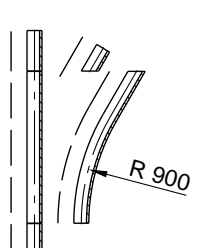
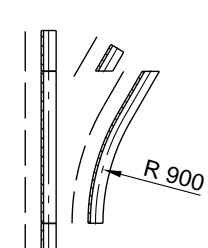
kg [kg] 3,900	Track switch left		Track switch right	
	right	left	right	left
Conductor line left	 9309.3536.2	 9309.3537.2	 9309.3540.2	 9309.3541.2
Conductor line right	 9309.3538.2	 9309.3539.2	 9309.3542.2	 9309.3543.2

6.32 Interlocking devices

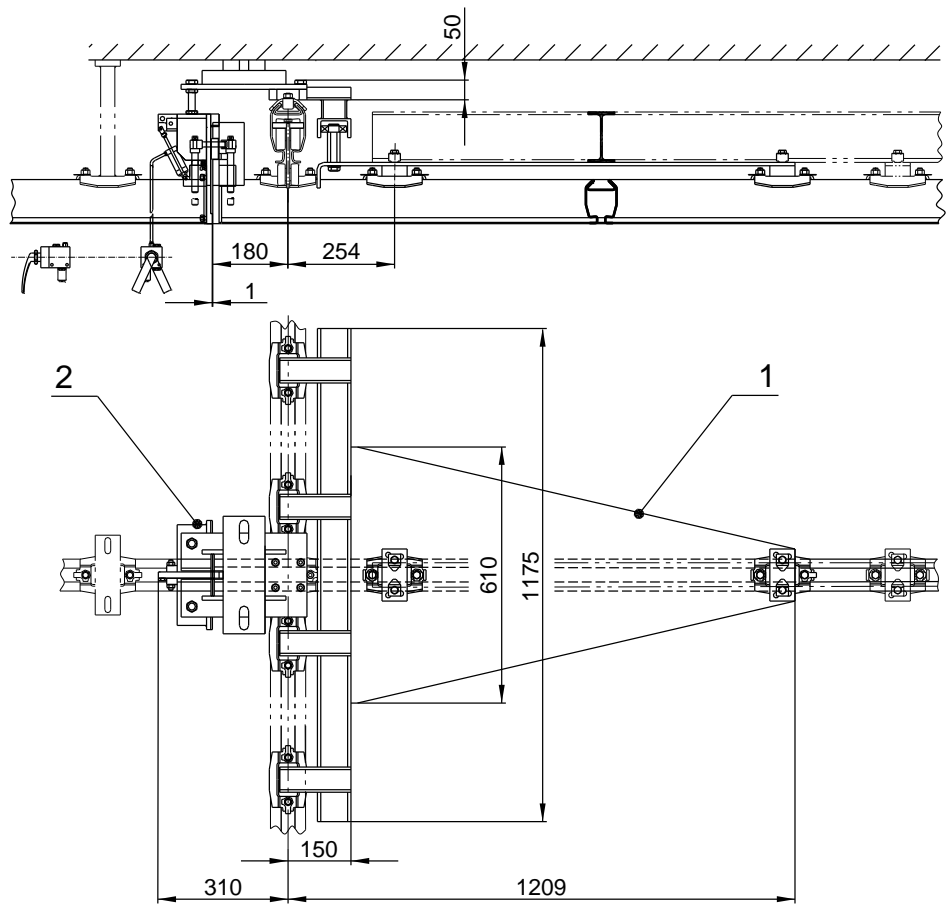



Version: Steel, galvanised. Pneumatic circuit.



Use: Crossing from the crane bridge suspended crane to an adjacent monorail.

Note: A conductor line or C-rail must be mounted on the opposite side of the lock. The operation is installed on the branch line.

Guide side (Item 1)

Crane track	Crane bridge	 [kg]	 [kg]		N°
GISKB I	GISKB I EQB	42.300	800		9309.4523.2
	GISKB II EQB	43.500	1600		9309.4526.2
GISKB II	GISKB I EQB	43.200	800		9309.4525.2
	GISKB II EQB	42.600	1600		9309.4524.2

Operator side (Item 2)

Crane track	Crane bridge	 [kg]	 [kg]		N°
GISKB I	GISKB I EQB	35.500	800		9309.4533.2
	GISKB II EQB	35.700	1600		9309.4534.2
GISKB II	GISKB I EQB	35.500	800		9309.4533.2
	GISKB II EQB	35.700	1600		9309.4534.2

7 Power supply

7.1 Trailing cable

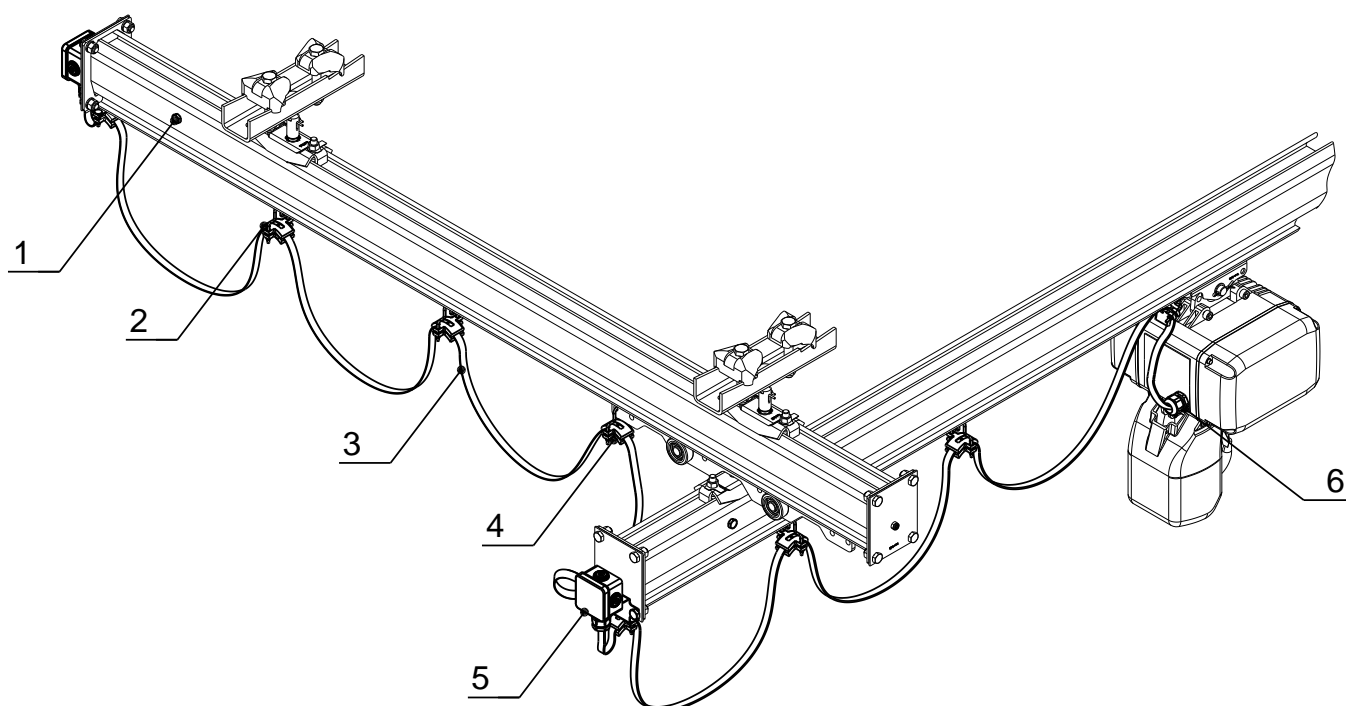

Item	 [kg]	Designation	N°
1	0.080	Traction limit	9309.3036.4
2	0.095	Cable carriage with 2 wheels, curve-going	9309.3040.4
3	0.130	Flat cable, 4 x 1.5 mm ²	9055.0300
4	0.040	Cable fixing part	9309.3069.4
5	0.300	Terminal box complete	9309.3037.4
6	0.050	Cable gland, M25 x 1.5, FK, PVC	9055.3107

7.2 C-rail

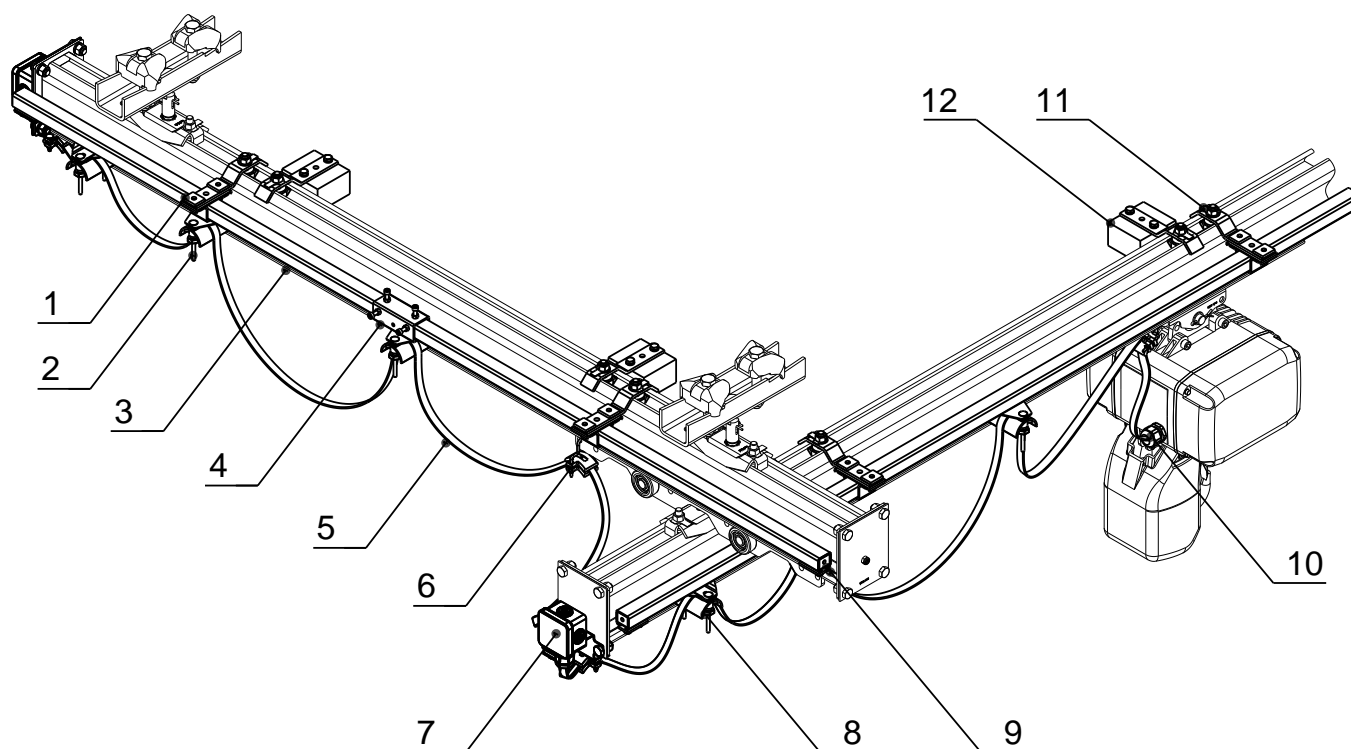

Item	 [kg]	Designation	N°
1	0.250	Suspension	9057.4200
2	0.300	Cable carriage	9057.4250
3	1.500	C-rail, 1 m	9309.3046.4
	3.000	C-rail, 2 m	9309.3047.4
	4.500	C-rail, 3 m	9309.3048.4
	6.000	C-rail, 4 m	9309.3049.4
	7.500	C-rail, 5 m	9309.3050.4
	9.000	C-rail, 6 m	9309.3051.4
4	0.300	Connector	9057.4150
5	0.130	Flat cable, 4 x 1.5 mm ²	9055.0300
6	0.040	Cable fixing part	9309.3069.4
7	0.300	Terminal box complete	9309.3037.4
8	0.200	Cable end clamp	9057.4100
9	0.150	C-rail stop	9057.4300
10	0.050	Cable gland, M25 x 1.5, FK, PVC	9055.3107
11	0.400	Clamping device complete, a = 100	9309.3045.4
12	2.750	Counterweight	9309.3143.3

7.3 Conductor line

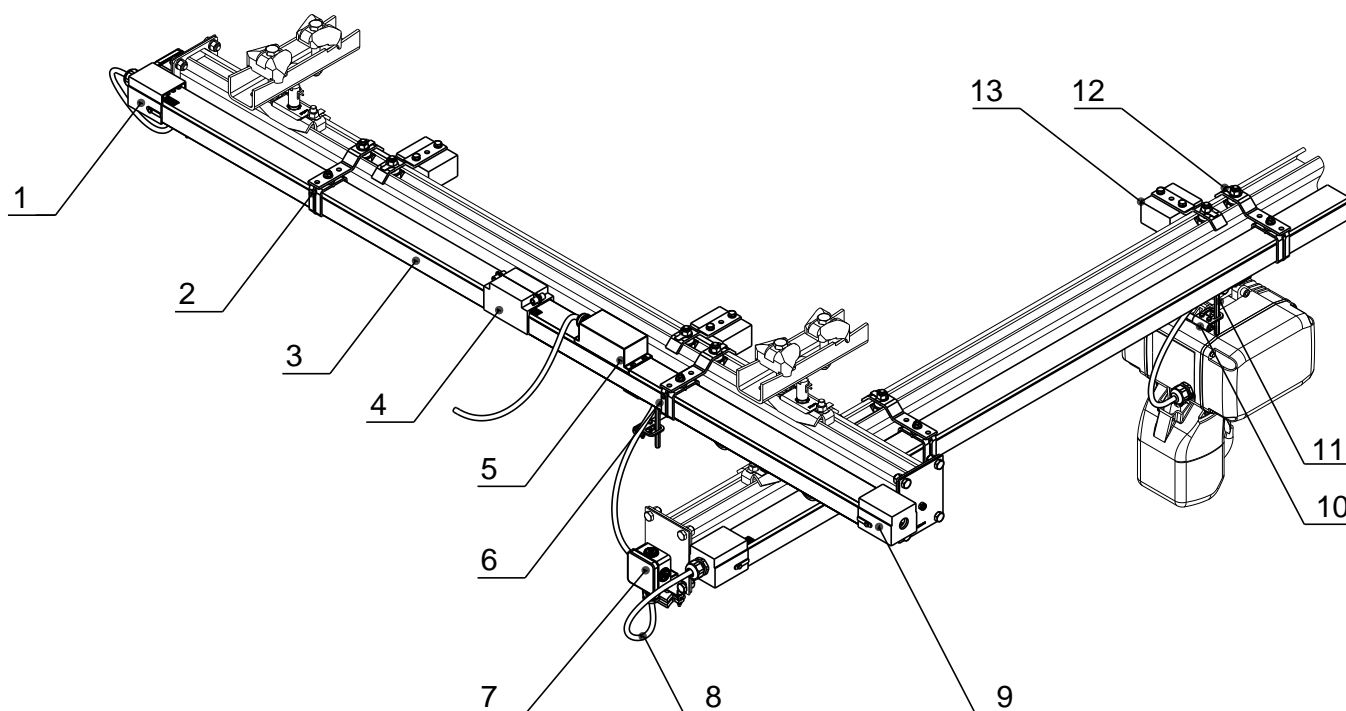

Item	 [kg]	Designation	N°
1	0.100	Power feed, EVD4	9309.3127.4
2	0.050	Suspension, VA806	9057.0103
3	1.100	Conductor line VA24, 4-pin, 1 m	9309.3058.4
	2.200	Conductor line VA24, 4-pin, 2 m	9309.3059.4
	3.300	Conductor line VA24, 4-pin, 3 m	9309.3060.4
	4.400	Conductor line VA24, 4-pin, 4 m	9309.3061.4
	5.500	Conductor line VA24, 4-pin, 5 m	9309.3062.4
4	0.100	Connection cap, VA804	9057.0552
5	0.100	Electrical supply at centre	9309.3124.4
6	0.050	Fixed suspension, VA850	9057.0104
7	0.300	Terminal box complete	9309.3037.4
8	0.200	Connection cable	9309.3071.4
9	0.100	End cap, VA802	9057.0151
10	0.110	Driving pin	9309.3070.4
11	0.600	Current collector trolley, PM425C, Standard	9057.0400
12	0.400	Clamping device complete, a = 100	9309.3045.4
13	2.750	Counterweight	9309.3143.3

7.4 Internal conductor line

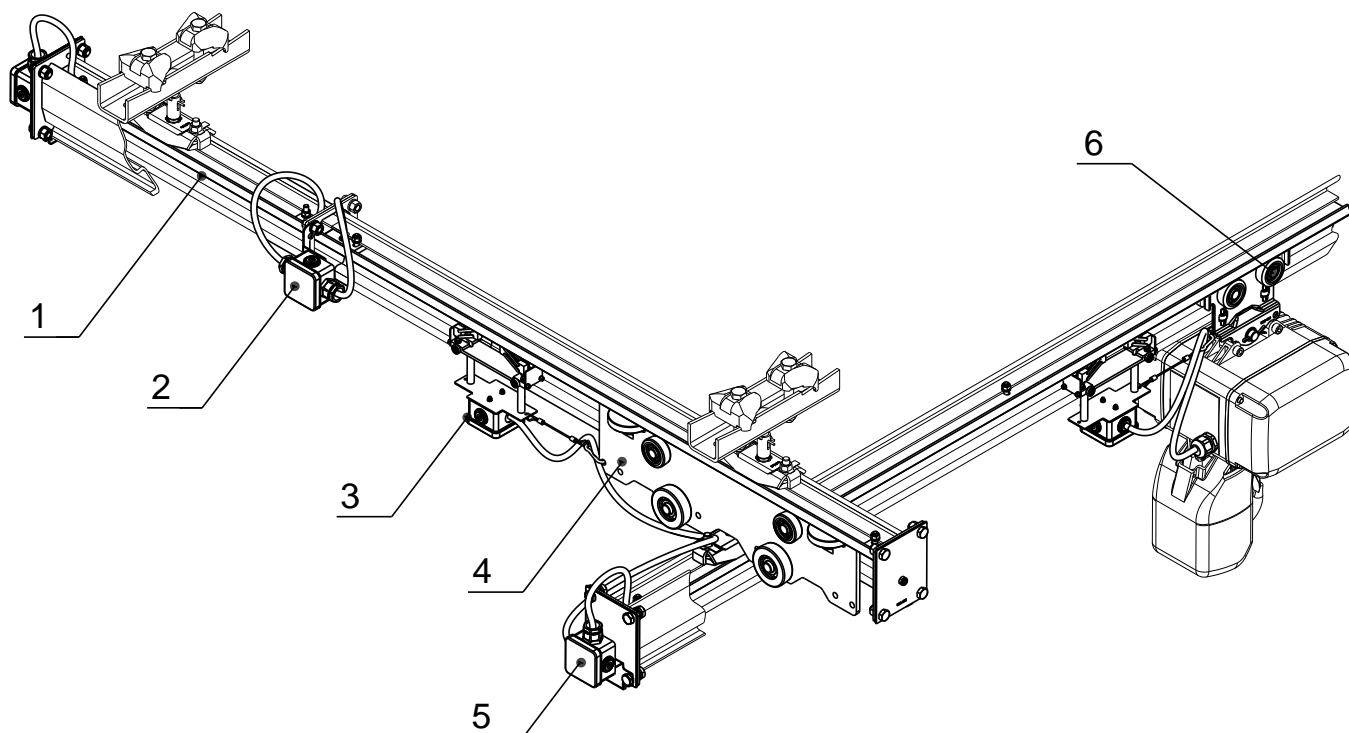

Item	 [kg]	Designation	N°
1	17.000	Conductor line GISKB II ST, 4-pin, 1 m	9309.4000.3
	33.000	Conductor line GISKB II ST, 4-pin, 2 m	9309.4001.3
	49.000	Conductor line GISKB II ST, 4-pin, 3 m	9309.4002.3
	64.500	Conductor line GISKB II ST, 4-pin, 4 m	9309.4003.3
	80.500	Conductor line GISKB II ST, 4-pin, 5 m	9309.4004.3
	96.500	Conductor line GISKB II ST, 4-pin, 6 m	9309.4005.3
	112.000	Conductor line GISKB II ST, 4-pin, 7 m	9309.4006.3
	128.000	Conductor line GISKB II ST, 4-pin, 8 m	9309.4007.3
2	0.180	Junction box GISKB II ST	9309.4021.4
3	2.400	Current collector trolley GISKB II ST, horizontal curves	9309.4032.3
4	5.500	Rolling apparatus EQB GISKB II ST, P max. = 800 kg	9309.4011.3
	6.000	Rolling apparatus DQB GISKB II ST, P max. = 800 kg	9309.4012.3
5	0.700	Lid insulated GISKB II ST, power feed	9309.4018.4
6	1.400	Trolley GISKB II ST, P max. = 500 kg	9309.4010.3

7.5 Components

Terminal box complete

Profile	 [kg]	N°
GISKB I + II	0.300	9309.3037.4

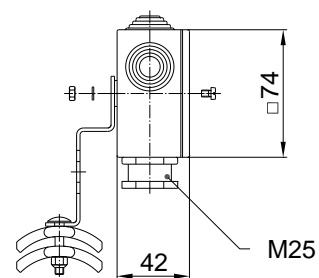

Cable carriage with 2 wheels, curve mobility

Profile	 [kg]	N°
GISKB I + II	0.095	9309.3040.4

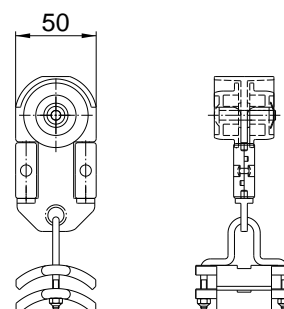

Traction limit

Profile	 [kg]	N°
GISKB I + II	0.080	9309.3036.4

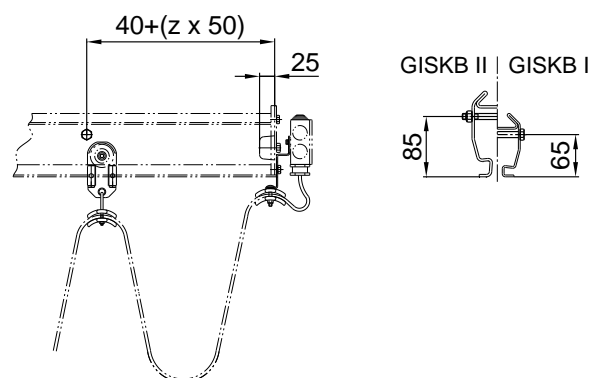

Flat cable

Type	 [kg/m]	N°
4 x 1.5 mm ²	0.130	9055.0300

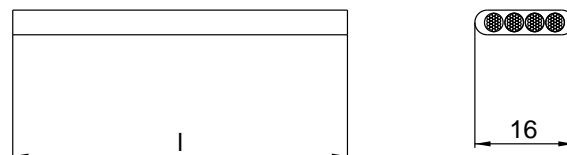

Round cable, shielded

Type	 [kg/m]	N°
7 x 1.0 mm ²	0.200	9055.0028

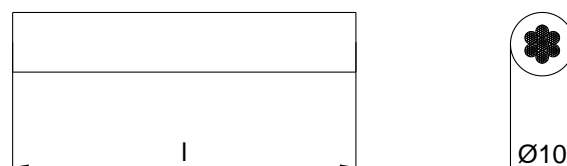

Cable fixing part

Profile	 [kg]	N°
GISKB I + II	0.040	9309.3069.4

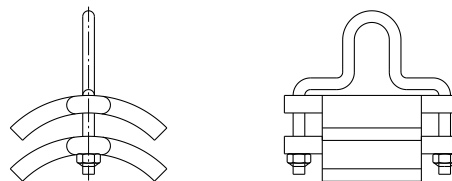

Cable gland

Type	 [kg]	N°
M25 x 1.5, FK	0.050	9055.3107

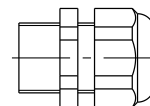

Clamping device complete

Profile	 [kg]	a [mm]	N°
GISKB I + II	0.400	100	9309.3045.4
GISKB I + II	0.750	300	9309.3123.4

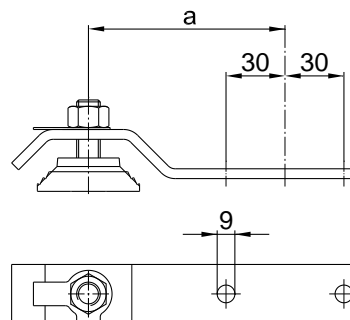

Counterweight

Profile	 [kg]	a [mm]	N°
GISKB I + II	2.750	100	9309.3143.3

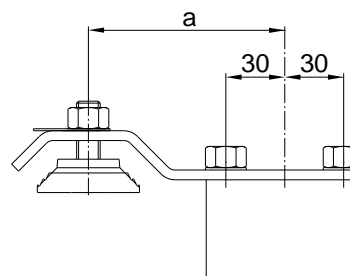

Use with pendulating suspension (at intervals of 2500 mm).

C-rail (Intermediate lengths upon request)

Type	 [kg]	N°
l = 1 m	1.500	9309.3046.4
l = 2 m	3.000	9309.3047.4
l = 3 m	4.500	9309.3048.4
l = 4 m	6.000	9309.3049.4
l = 5 m	7.500	9309.3050.4
l = 6 m	9.000	9309.3051.4

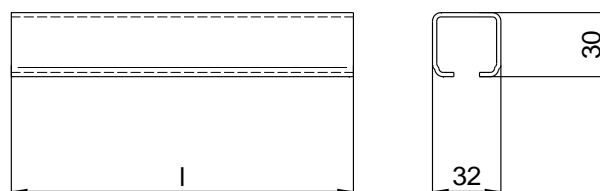

Cable carriage

Profile	 [kg]	N°
C-rail	0.300	9057.4250

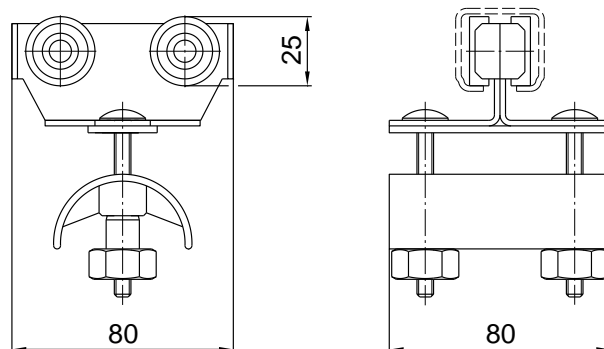
**Suspension**

Profile	 [kg]	N°
C-rail	0.250	9057.4200

**Connector**

Profile	 [kg]	N°
C-rail	0.300	9057.4150

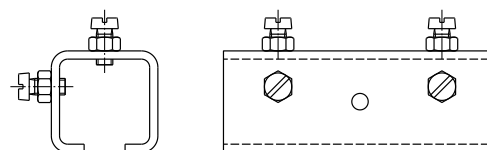
**C-rail stop**

Profile	 [kg]	N°
C-rail	0.150	9057.4300

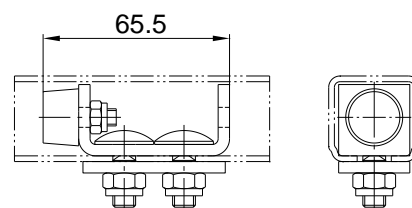
**Cable end clamp**

Profile	 [kg]	N°
C-rail	0.200	9057.4100

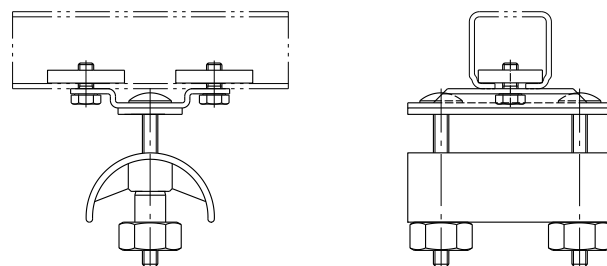

Conductor line VA24, 4-poles (other lengths on request)

Type	 [kg]	N°
l = 1 m	1.100	9309.3058.4
l = 2 m	2.200	9309.3059.4
l = 3 m	3.300	9309.3060.4
l = 4 m	4.400	9309.3061.4
l = 5 m	5.500	9309.3062.4

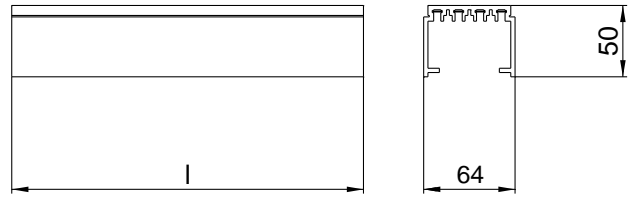

Driving pin

Profile	 [kg]	N°
GISKB I + II	0.110	9309.3070.4

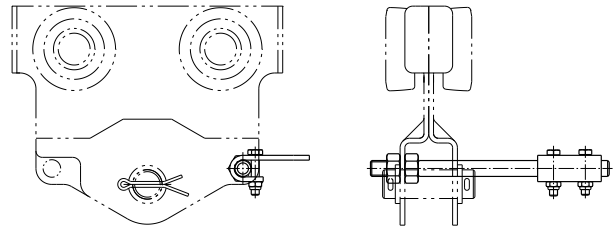

Current collecting trolley, PM425C

Type	 [kg]	N°
Standard	0.600	9057.0400
Curve mobility	0.600	9057.0408

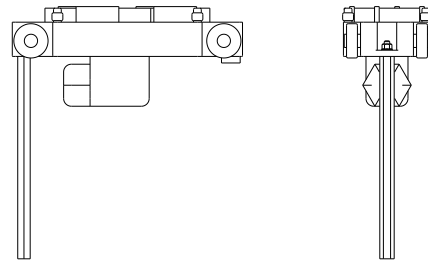

Power feed, EVD4

Profile	 [kg]	N°
Conductor line	0.100	9309.3127.4

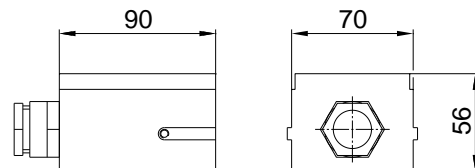

Suspension, VA806

Profile	 [kg]	N°
Conductor line	0.050	9057.0103

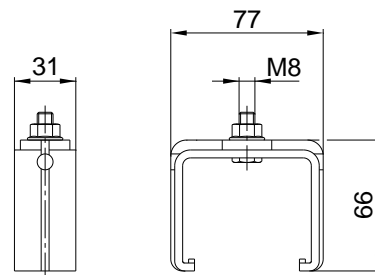

Fixed suspension, VA850

Profile	 [kg]	N°
Conductor line	0.050	9057.0104

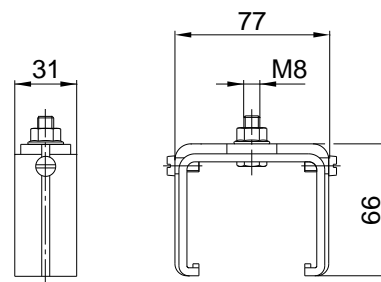

Connection cap, VA804

Profile	 [kg]	N°
Conductor line	0.100	9057.0552

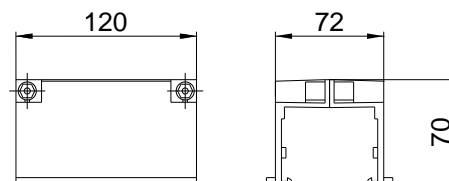

End cap, VA802

Profile	 [kg]	N°
Conductor line	0.100	9057.0151

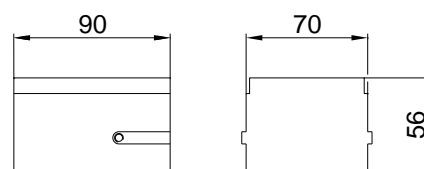

Connection cable

Profile	 [kg]	N°
GISKB I + II	0.200	9309.3071.4

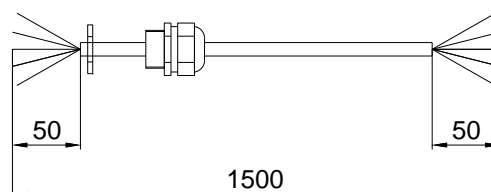

Electrical supply at centre

Profile	 [kg]	N°
Conductor line	0.100	9309.3124.4

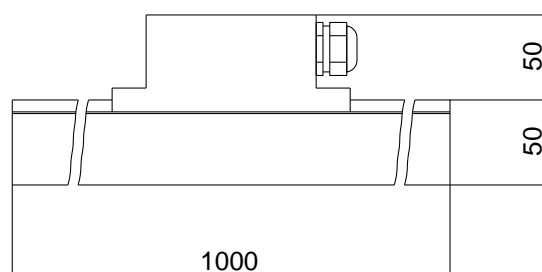

Customer data			
Company _____		Date _____	
Address _____		Customer number _____	
Postal code _____		Phone number _____	
City - Country _____		Fax number _____	
Responsible person _____		Function _____	
Crane system GISKB			
<input type="checkbox"/> Single crane bridge		<input type="checkbox"/> Double crane bridge	<input type="checkbox"/> Suspended track
Load capacity _____ kg			
Length of the girder L _____ mm		Length of the track B _____ mm	
Span W _____ mm		Height of the room _____ mm	
Required lifting height _____ mm		Sketch see on back !	
Suspension			
Kind of suspension		<input type="checkbox"/> pendulating short	<input type="checkbox"/> pendulating from rod _____ mm
		<input type="checkbox"/> rigid	
Ceiling construction		<input type="checkbox"/> Concrete ceiling	<input type="checkbox"/> Steel girder _____
		<input type="checkbox"/> Wooden truss _____	
Suspension distance		<input type="checkbox"/> variable	<input type="checkbox"/> given _____ mm
Travelling motions			
Movement of the trolley		<input type="checkbox"/> push type	<input type="checkbox"/> electrical type
		<input type="checkbox"/> 1 speed	<input type="checkbox"/> 2 speeds
			<input type="checkbox"/> _____ m/min
Movement of the bridge		<input type="checkbox"/> push type	<input type="checkbox"/> electrical type
		<input type="checkbox"/> 1 speed	<input type="checkbox"/> 2 speeds
			<input type="checkbox"/> _____ m/min
Hoist			
<input type="checkbox"/> GIS Electric chain hoist		<input type="checkbox"/> Hand lifting gear	<input type="checkbox"/> _____
Type _____		Lifting capacity _____ kg	
Lifting speed		<input type="checkbox"/> 1 speed	<input type="checkbox"/> 2 speeds
			<input type="checkbox"/> _____ m/min
Lifting height (standard 3 m) _____ m		Operating time per day _____ hours	
Control / Electricity			
Control		<input type="checkbox"/> Operation from control switch of hoist	<input type="checkbox"/> Ideal control (control switch is movable independently)
Voltage		<input type="checkbox"/> 3 Ph 400V, 50Hz	<input type="checkbox"/> 1 Ph 230V, 50Hz
			<input type="checkbox"/> _____ V _____ Hz
Longitudinal power supply		<input type="checkbox"/> without	<input type="checkbox"/> Trailing cable
		<input type="checkbox"/> Contact line	<input type="checkbox"/> C-rail
Transversal power supply		<input type="checkbox"/> without	<input type="checkbox"/> Trailing cable
		<input type="checkbox"/> Contact line	<input type="checkbox"/> C-rail
Location of the crane			
<input type="checkbox"/> Workshop		<input type="checkbox"/> outdoor	<input type="checkbox"/> near acids/alkaline solutions
<input type="checkbox"/> _____			
Installation			
<input type="checkbox"/> by GIS		<input type="checkbox"/> by customers	<input type="checkbox"/> Stacker truck is available at building site
Additional technical data/Customer requirements			
Required offer			
<input type="checkbox"/> Short offer		<input type="checkbox"/> Approximate price	<input type="checkbox"/> Offer required by _____
<input type="checkbox"/> Detailed offer		<input type="checkbox"/> Date of realisation / desired delivery time _____	
GIS AG		Enclosures	
swiss lifting solutions		<input type="checkbox"/> Sketch _____	
CH - 6247 Schötz		<input type="checkbox"/> Plan/Drawing _____	
Phone +41 (0)41 984 11 33		<input type="checkbox"/> _____	
E-mail tel@gis-ag.ch			

